



Customer Driven.
Community Focused.SM

Final Deliverable – 1

System Levelized Cost of Electricity (System LCOE) Methodology

Prepared for the
Austin SHINES Project

Federal Agency
U.S. Department of Energy

Award Number
DE-EE30007177

Project Period
Start: February 1, 2016 / End: March 31, 2020

Final Deliverable - 1

System Levelized Cost of Electricity (System LCOE) Methodology

How to Read this Document

The audience for this report includes utilities and anyone looking to quantify the System Levelized Cost of Energy (System LCOE) to Serve Load. The Austin SHINES solution seeks to enable 25% photovoltaic (PV) penetration (by energy) with a System LCOE \leq \$0.14/kWh. This tool and documented technique serves as a replicable and configurable metric for other utilities, across multiple jurisdictions. The resulting Austin Energy SHINES solution can enable 25% PV penetration (by energy) with a System LCOE \leq \$0.14/kWh. Deliverables include the following report in addition to software tools used to quantify the System LCOE in the project. Report elements define the System LCOE methodology, the Austin SHINES baseline and 25% PV system in which the method is applied, control scheme, description of application, and reflective summary of methodology key findings. The report differs from Final Deliverable 5, which seeks to discuss the outcomes of methodology application from multiple scenarios to identify the optimal mix and configuration of assets, which meet the criteria for 25% PV penetration (by energy) with System LCOE \leq \$0.14/kWh.

Table of Contents

Section 1	Executive Summary	7
Section 2	System Levelized Cost of Energy Methodology	8
2.1	Definition of System LCOE	9
2.2	Key Assumptions.....	10
2.3	Overview of Circuit Analysis and System LCOE Calculation	11
2.4	Economic Data	12
2.4.1	Distribution Infrastructure Cost Data	12
2.4.2	Wholesale Markets Cost Data	13
2.4.3	DER Cost Data	15
2.5	System Boundary	15
2.6	System Timescales	16
2.7	Circuit Model	17
2.7.1	Base Network Model	18
2.7.2	Time-series Data: Solar	18
2.7.3	Time-series data: Load.....	19
Section 3	Baseline System	24
3.1	System Characterization and Key Performance Indicators	24
3.1.1	Kingsbery (KB)	24
3.1.2	Mueller (MU)	28
3.2	Baseline System LCOE result	31
Section 4	System with 25% Solar Penetration	32
4.1	Solar PV generation scenarios	32
4.1.1	25% solar PV generation.....	33
Section 5	Definition of Controls	38
5.1	Controls Scenarios	38
5.2	SHINES Control Applications.....	42
5.2.1	Peak Load Reduction	42
5.2.2	Real Time Price Dispatch	43
5.2.3	Energy Arbitrage	44
5.2.4	Congestion Management	44
5.2.5	Demand Charge Reduction.....	45
5.2.6	Voltage Support	46
Section 6	System LCOE Methodology Application	49
Section 7	Summary of Key Findings	51
7.1	Computational Burden	51
7.2	Impact of Controls and Applications	51
Appendix	53	
A.	Fielded DER Costs	53
B.	DER Costs	54

Table of Figures

Figure 1-1 System LCOE Controls Scenarios and Metrics	7
Figure 1-2 Example set of System LCOE results	8
Figure 2-1 Illustrative System Boundary	9
Figure 2-2 System LCOE simplified equation	10
Figure 2-3 Overview of circuit analysis process	11
Figure 2-4 Austin SHINES System Assets	16
Figure 2-5 Austin SHINES System Time Scales and application Time Scales	17
Figure 2-6 A sample of Pecan Street solar generation time-series data	18
Figure 2-7 Correlation between the KB feeder-head demand and independent variables a) Austin Energy total load, b) temperature, and c) solar irradiance	19
Figure 2-8 MU feeder-head data from 03/07/2016 to 03/20/2016; solid blue line: actual data, solid red line: estimated data.....	20
Figure 2-9 Sample Lodestar data; data is available until the end of 3/16; transition to CC LP happened in 4/16.	21
Figure 2-10 Sample CC LP data; data is available beginning 4/16	21
Figure 2-11 Concatenation of Lodestar (red) and CC LP (blue) data in the hourly cumulative consumption format ...	22
Figure 2-12 A sample of Pecan Street load consumption time-series data	22
Figure 2-13 EV data samples; (a) multifamily (b) EV360 TOU (c) Pecan Street.....	23
Figure 2-14 Sample of a data cluster; colorful lines: cluster members, black line: cluster representative	24
Figure 3-1 KB aggregated real power demand	25
Figure 3-2 KB aggregated solar power generation	25
Figure 3-3 Comparison between gross load, solar generation and net load for KB.....	26
Figure 3-4 Comparison between gross load, solar generation and net load for KB; a sample week in March (shoulder season).....	26
Figure 3-5 Voltage heatmap of KB at 12:00 PM on March 24, 2016, baseline solar.....	27
Figure 3-6 Comparison between gross load, solar generation and net load for KB; a sample week in June (peak season).....	27
Figure 3-7 Voltage heatmap of KB at 12:00 PM on June 9, 2016, baseline solar	28
Figure 3-8 MU aggregated real power demand.....	28
Figure 3-9 MU aggregated solar power generation.....	29
Figure 3-10 Comparison between gross load, solar generation and net load for MU.....	29
Figure 3-11 Comparison between gross load, solar generation and net load for MU; a sample week in March (shoulder season)	30
Figure 3-12 Voltage heatmap of MU at 12:00 PM on March 24, 2016, baseline solar.....	30
Figure 3-13 Comparison between gross load, solar generation and net load for MU; a sample week in June (peak season).....	31
Figure 3-14 Voltage heatmap of MU at 12:00 PM on June 9, 2016, baseline solar	31

Figure 4-1 Comparison between gross load, solar generation and net load for KB at 25% solar penetration..... 33

Figure 4-2 Comparison between gross load, solar generation and net load for KB at 25% solar penetration; a sample week in March (shoulder season) 33

Figure 4-3 Heatmap of KB at 12:00 PM on March 24, 2016, 25% solar penetration 34

Figure 4-4 Comparison between gross load, solar generation and net load for KB at 25% solar penetration; a sample week in June (peak season) 34

Figure 4-5 Voltage heatmap of KB at 12:00 PM on June 9, 2016; 25% solar penetration 35

Figure 4-6 Comparison between gross load, solar generation and net load for MU at 25% solar penetration..... 35

Figure 4-7 Comparison between gross load, solar generation and net load for MU at 25% solar penetration; a sample week in March (shoulder season) 36

Figure 4-8 Voltage heatmap of MU at 12:00 PM on March 24, 2016; 25% solar penetration 36

Figure 4-9 Comparison between gross load, solar generation and net load for MU at 25% solar penetration; a sample week in June (peak season) 37

Figure 4-10 Voltage heatmap of MU feeders at 12:00 PM on June 9, 2016; 25% solar penetration 37

Figure 5-1 Current Peak Value in June 2019 42

Figure 5-2 Sample real-time price dispatch report 44

Figure 5-3 DCR algorithm (proxy for STEM aggregator DCR algorithm) performance 46

Figure 5-4 Higher limit (top red shaded area), lower limit (bottom red shaded area) and control (blue shaded are in the middle) zones 47

Figure 5-5 Voltage Support Application performance 48

Figure 6-1 Example set of System LCOE results; MU circuit, two 0.99MW/2 MWh utility ESS, 4.9MW distributed PV 49

Figure 6-2 System LCOE results; MU circuit, two 0.99MW/2 MWh utility ESS, 4.9MW distributed PV 49

Table of Tables

Table 2-1: Present and Forecasted 2020 Values for 4CP Calculations 14

Table 2-2: Network Topology Models 18

Table 3-1: Baseline System LCOE 32

Table 5-1: Controls Scenarios 39

Table 6-1: Scenario 3 49

Table 6-2: System LCOE results for the MU circuit, two 0.99MW/2 MWh utility ESS, 4.9MW distributed PV 50

Section 1 Executive Summary

The Austin SHINES solution is a Distributed Energy Resource (DER) management platform that optimizes value for a system with a high penetration of distributed photovoltaic (PV) generation, while maintaining the traditional power quality and reliability associated with electric grid service. Austin SHINES recognizes that emerging DER assets such as solar and battery energy storage are part of an integrated, interconnected grid system and the benefits of these resources are maximized only when they are holistically coordinated with one another and other grid assets. This project developed and deployed a DER management platform engaging multiple advanced controls methodologies, to demonstrate and evaluate a fleet of diverse DER assets, deployed at several locations among Austin Energy’s customers and distribution system. By operating these assets as a coordinated system, the Austin SHINES solution aims to create and demonstrate DER deployment and control methodologies which enable a grid ecosystem to serve load at a technical cost of less than the U.S. Department of Energy SHINES program metric of \$0.14/kW, in a defined boundary, while enabling a high penetration of distributed solar.

This report documents the creation and use of the System Levelized Cost of Energy to serve load metric (System LCOE). A System LCOE encompasses the holistic, system-level costs and benefits of all resources and enables them to be evaluated based on their ability to support an efficient and low-cost integrated grid ecosystem. The System LCOE is used as a key metric in the design and optimization of a holistic control strategy, as illustrated in Figure 1-1. It is used to calculate the differential value of integrated DER management, as compared to the value of uncoordinated DERs, and is not meant to be a ratemaking exercise or to calculate the tariff to be paid by customers. The purpose of the System LCOE is to be a clear metric, absent of ownership considerations, for identifying the lowest cost DER configuration and controls scheme. Once the lowest cost solution is identified, economic exchange mechanisms for enabling that solution can be developed; that stage is a second step, to be carried out after the System LCOE calculation. The focus of this work is the calculation of the System LCOE as a mechanism for system design; the question of which costs should be borne by which entities in the system is outside the scope of this project.

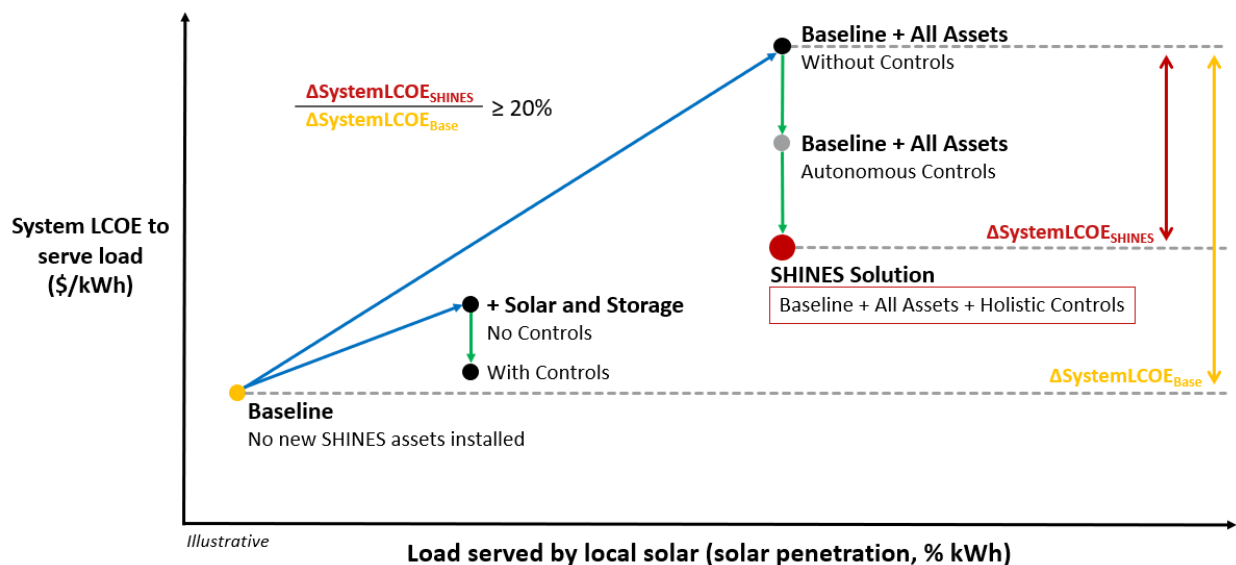

Figure 1-1 System LCOE Controls Scenarios and Metrics

The Austin SHINES project has two key metrics, shown in Figure 1-1, for System LCOE:

- $SystemLCOE_{SHINES} < \$0.14/kWh$
- Modeled $\Delta SystemLCOE_{SHINES} / \Delta SystemLCOE_{Base} \geq 20\%$ at same solar penetration

The first metric is easily achieved by every scenario considered. The goal was set when the Department of Energy’s SHINES Funding Opportunity Announcement was written in 2015 and was a more difficult target at the time. Due

mostly to rapidly declining costs for DERs and the significant decrease in the Electric Reliability Council of Texas (ERCOT) energy market prices, which results in lower net cost of energy purchases, the System LCOE is well below this target for all scenarios considered.

The second metric (hereinafter %delta metric) asks that the holistic controls reduce the incremental cost above the baseline of going to a high solar penetration future by at least 20% as compared to the case of a DER deployment with no sophisticated controls. Many comparison sets will be created throughout this project, including contrasting DER deployment strategies. These comparison sets were generated in plots like Figure 1-2.

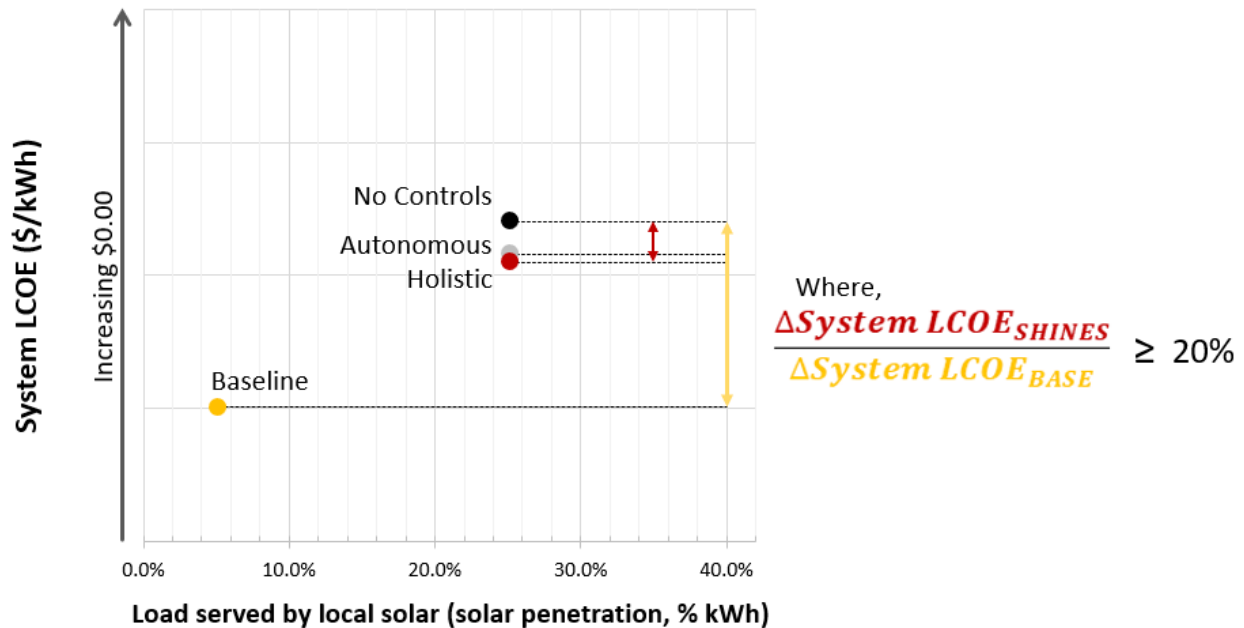

Figure 1-2 Example set of System LCOE results

In general, the %delta metric can be met when the wholesale market value that DER can capture is significantly enhanced by holistic controls, or when the case with no control involves significant system integration costs.

This document is organized as follows:

- Section 2 describes the methodology of the System LCOE metric
- Section 3 provides the System LCOE results for the baseline system
- Section 4 studies the impact of higher solar penetration on the system
- Section 5 discusses DER controls in the Austin SHINES project
- Section 6 demonstrates an example of the implementation of the System LCOE methodology, the basis for understanding Final Deliverable Report 5, and finally
- Section 7 summarizes the methodology findings and takeaways.

Section 2 System Levelized Cost of Energy Methodology

A key deliverable of the Austin SHINES project documented in this report is the definition and use of the System Levelized Cost of Energy metric (System LCOE) that encompasses the holistic, system-level costs and benefits of all resources. This enables resources to be evaluated based on their ability to support an efficient and low-cost integrated grid ecosystem. This methodology will be first applied to the Austin SHINES project, and has broad applicability by other utilities, in other regions.

Over the course of this 50-month project, Austin Energy and partners have installed more than 3MW of distributed storage, smart inverters, a DER control platform, and other enabling technologies utilizing customer and utility locations and multiple aggregation models. These resources were integrated and optimized at the utility level using a variety of management strategies. DER assets and control methodologies were designed with an aim of achieving:

- A credible pathway to a System LCOE of \$0.14/kWh or less by 2020
- A holistic controls design with a 20% decrease in System LCOE, as compared to the no controls case
- Ability to enable high (25%) penetration of distributed solar generation
- And maintaining acceptable standards of power quality

2.1 Definition of System LCOE

Designing and operating the electric grid requires the coordination of numerous assets that each contribute to grid reliability, power quality, and efficiency in an integrated fashion. No individual asset is isolated but is instead a dependent and supportive element of a holistically integrated system where the collective contributions of diverse assets result in utility-grade grid performance. Evaluating a single asset in isolation masks potentially negative system impacts and prevents the inclusion of benefits that arise from assets working together.

The System LCOE metric addresses this problem by including the combined costs and benefits of all assets working together within the defined system boundary to reliably serve load. This metric reflects the fact that any one device impacts the performance of other devices and thus the overall performance of the system. Rather than focusing on the cost and performance of a single asset (which, by itself, cannot meet the full needs of providing reliable grid service), the System LCOE encompasses the costs and performance of all assets within a defined distribution circuit system, which, together, make up a reliable grid.

A conceptual diagram of an example system is shown below in Figure 2-1. Energy and services which cross the system boundary are quantified along with the capital and operating costs and value of all assets within the system.

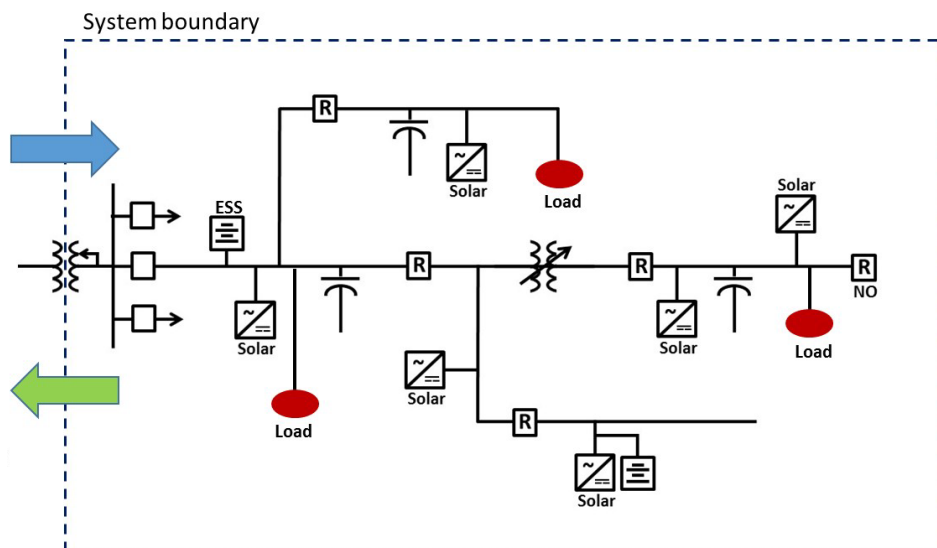

Figure 2-1 Illustrative System Boundary

Figure 2-2 below shows the simplified System LCOE equation. Economic data from Austin Energy's 2016 cost of service rate case, ERCOT markets, and DER cost estimation tools including the National Renewable Energy Laboratory's (NREL) System Advisor Model (SAM) are supplemented with circuit analysis tools to properly represent the economics of an entire distribution circuit.

$$\begin{array}{c}
 \boxed{\text{System LCOE to Serve Load (\$/kWh)}} \\
 = \\
 \frac{
 \begin{array}{c}
 \boxed{\text{Capital cost of all equipment within system (\$)}} + \boxed{\text{Operating cost of all equipment within system (\$)}} + \boxed{\text{Net value of energy, capacity, and services that cross system boundary (\$)}}
 \end{array}
 }{
 \boxed{\text{All load served within the system (kWh)}}
 }
 \end{array}$$

Figure 2-2 System LCOE simplified equation

The Austin SHINES project used performance data from field assets and control systems combined with market and economic information to calculate and compare the System LCOE of the defined Austin Energy distribution system under a variety of scenarios, with different assets and controls present. The project first calculates a baseline System LCOE metric that includes no SHINES assets (the yellow dot in Figure 1-1). The design and deployment of each DER assets includes a calculation of that individual asset’s impact on the System LCOE. At the culmination of the design phase (described in Final Deliverable 3), the System LCOE metric was calculated with all assets and control schemes included (the red dot in Figure 1-1). This metric will set the performance target by which the field and simulation demonstration phase will be evaluated. The goal of this modeling effort is to identify the optimal mix of devices and control schemes that result in the lowest System LCOE, at the highest possible PV penetration.

The methodology for calculation of the System LCOE for the Austin SHINES project is developed in the following subsections of Section 2. Several key assumptions are briefly discussed in Section 2.2 in addition to an overview of the circuit analysis and System LCOE calculation in Section 2.3. The economic data that is used to calculate the System LCOE is discussed in Section 2.4. The system boundary is defined in Section 2.5, and system time scales are discussed and modeling time scales defined in Section 2.6. Finally, detailed calculations of control applications are discussed in Sections 2.7.

2.2 Key Assumptions

There are several assumptions implicit in the definition of System LCOE that are crucial to respect while using the metric for comparing DER deployment strategies or controls optimization:

1. The System LCOE metric does not determine which entity in the system should incur costs or own assets. It is not a ratemaking exercise or a calculation of expected cost to customers, nor is it a prediction of future prices. The purpose of the System LCOE metric is to calculate the total cost of the system that serves load, from a technical perspective, so the question of what DER deployment strategy and controls configuration would minimize the cost can be answered. The question of who should own assets could be taken up as a secondary consideration or negotiation in a later stage of analysis, after the optimal configuration is determined.
2. The System LCOE metric does not discriminate between any asset in the system (i.e., grid-side or Behind-the-Meter (BTM)). The meter is not an electrically significant point in the system. Because the question of ownership is not considered, the focus is maintained on the technically and economically optimal DER deployment strategy.
3. The technical System LCOE consists of hardware, software, control, and communications costs. Cost to society and externalities such as the social cost of carbon are not considered.
4. Credit is assigned to the value of services provided upstream. For example, if DERs provide Ancillary Services (AS) such as regulation, the value of those services crosses the system boundary, and is calculated as a negative contribution to the third term in the numerator (thus reducing the overall cost in the numerator).
5. Energy flows and services that do not cross the system boundary are not considered; energy flows and services that *do* cross the system boundary *are* considered. For example, consider the addition of DER assets deployed within the system boundary. The capital and O&M cost of assets inside the boundary will increase. Generation by solar PV will supply load inside of the boundary, and less energy will need to be purchased from wholesale markets, decreasing the cost of energy flows through the boundary, reflected in the third term in the numerator as a positive

value. Because there is energy lost in the cycling of batteries and prices vary with time, the shifting of energy from one time to another by energy storage will result in a decrease at some time intervals, and increase at other time intervals, and may lead to an incremental increase in the cost of the net, integrated wholesale energy purchases, also reflected in the third term of the numerator. Optionally, when the DER provides AS in the wholesale markets, which is a positive value that crosses the system boundary, this additional DER deployment will affect all three terms in the numerator. It will not change the total demand for energy inside the system boundary, and therefore will not change the denominator.

6. It is assumed that power quality and reliability of service is held to a consistent level when comparing scenarios. If a system configuration leads to a violation of ANSI C84.1 voltage limits, for example, then the configuration is not valid. Steps must be taken to bring the system back into compliance, which may involve increased costs reflected in the first two terms of the numerator, if additional voltage control equipment must be purchased and installed. Changes in the reliability of the system are not reflected in the System LCOE calculation, unless reliability degrades to the point where a system configuration is determined to be nonviable.

2.3 Overview of Circuit Analysis and System LCOE Calculation

The three-stage process for carrying out circuit analysis and the System LCOE calculations is summarized in Figure 2-3. This report contains discussion of the input data used at each stage of the process, the calculations carried out at each stage, and the results.

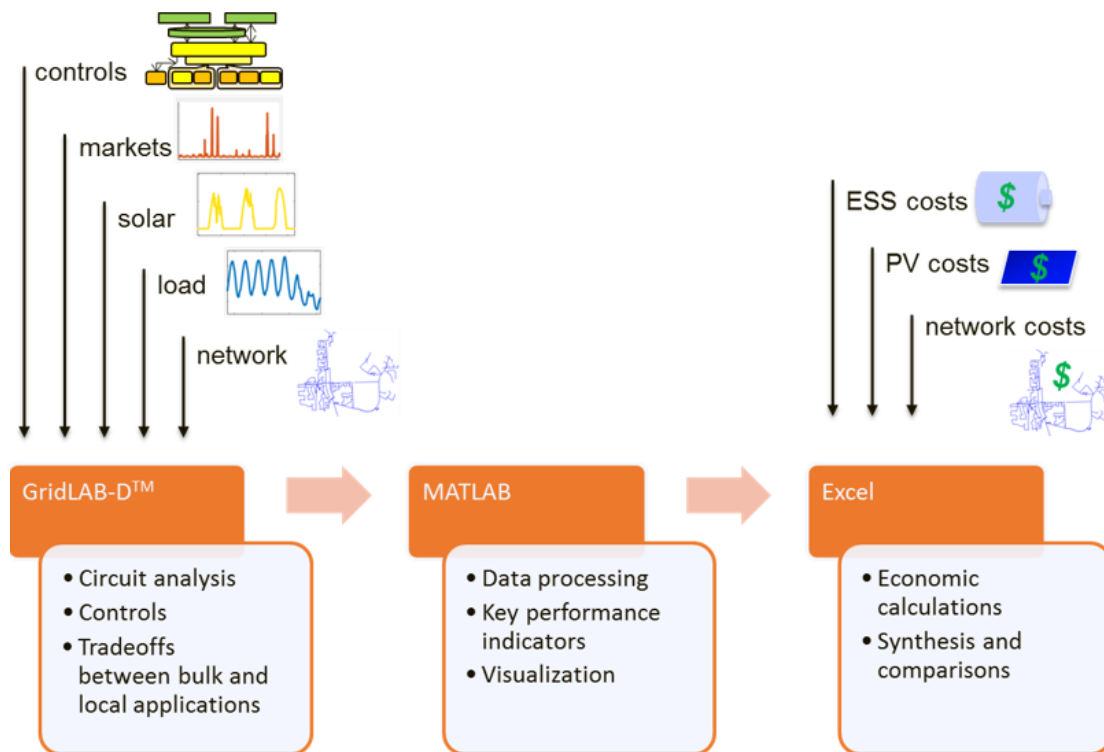

Figure 2-3 Overview of circuit analysis process

In the first stage, time-series simulations capture the full, detailed technical and economic interactions of all system elements in a model that fully represents the electrical characteristics of the SHINES feeders and objects inside the system. The input data required for this stage are:

- The control logic (discussed in Section 5)
- Time-series wholesale market data (discussed in Section 2.4.2)
- The network model (discussed in Section 2.7.1)
- Time-series solar data (discussed in Section 2.7.2)
- Time-series load data (discussed in Section 2.7.3)

The primary tool used for the first stage is GridLAB-D, a distribution system simulation tool whose development was supported by the DOE. GridLAB-D is a flexible, object-oriented simulation environment that implements quasi-static time-series simulations. Control applications focused on local power quality and control (voltage support and congestion management) are instantiated directly in the GridLAB-D modeling environment. Control applications involving DER response to wholesale market signals are captured by operating an instance of the Austin SHINES Distributed Energy Resource Optimizer (DERO) in a software-in-the-loop configuration.

In the second stage, data processing and visualization, the information that is generated by simulations is processed and synthesized and key performance indicators are calculated. For example, the simulation produces time-series data of quantities like power consumed by loads on the feeder, power generated by solar PV, and power purchased from ERCOT wholesale markets, and at this stage metrics like solar penetration level by energy are calculated. This is also the stage where visualizations of circuit modeling results are created, including full calendar year summaries, sample days, and spatial maps of qualities like voltage and power factor. MATLAB, a scientific computing scripting language, is used to carry out the calculations in this stage.

In the third stage, economic calculations, a Microsoft Excel-based tool calculates the System LCOE for the various scenarios.

At the highest level, there are three calculations as represented in Figure 1-1, (1) the baseline system, (2) the system with DERs without holistic controls, and (3) the system with DERs with holistic SHINES controls. In practice, the process is repeated from start to finish repeatedly as the configuration of DERs and the holistic SHINES controls are varied, and the System LCOE metric is used to systematically refine the design of the controls.

2.4 Economic Data

The data required to calculate the System LCOE metric as defined in Figure 2-2 will come from multiple sources. The source of cost data is discussed in this section.

2.4.1 Distribution Infrastructure Cost Data

For the baseline calculation, the primary source of cost data is Austin Energy's 2016 Cost of Service study (based on a FY2014 test year). The cost of service study determines Austin Energy's total revenue requirement by adding up all costs across different business functions and allocates them equitably to different customer classes. The study allocates all system costs to the various electric rate classes. It uses Austin Energy's accounting data, functionalized according to the FERC chart of accounts. Costs are captured at the system level and therefore cannot provide data on a locational basis. The study includes all the investment in system plant and their current debt service costs along with the system's operating and maintenance expenses and Power Supply Adjustment (PSA) costs. Therefore, the first three terms in the numerator of the System LCOE equation, on a system-wide basis, are discoverable. The cost of service takes a cash-flow approach and calculates the costs of operating the system over a typical test year. The year is a fiscal year (which starts on October 1), not a calendar year, but is weather-normalized and known and measurable adjustments are made.

The process of weather normalization adjusts actual revenue month sales to "normal" levels based on normal weather conditions, removing the effect of any extreme hot (or cold) weather. Austin Energy currently averages the past 20 years as the basis for weather normalizing the billing determinants. This allows a comparison between current energy and demand usage and the previous year's weather-normalized usage and the ability to assess positive or negative growth estimates by isolating (quantifying) the change in usage beyond normal weather patterns. Weather normalization is performed at the sector level but only on the Residential and Commercial sector sales. Industrial Sectors sales are deemed not significantly sensitive to weather patterns to require normalization.

For characterizing baseline system parameters, such as voltage control, transformer loading, etc., a power flow simulation of the system as it is today was carried out. This requires a network model of the system, metered power flow and voltage data as measured at the substation, customer meter data, and configuration of existing Advanced Distribution Management System (ADMS) controls, such as Volt-Var Optimization (VVO).

2.4.2 Wholesale Markets Cost Data

A significant fraction of the System LCOE total comprises charges incurred from participation in the ERCOT market, which administers the transmission system and wholesale markets.

2.4.2.1 Wholesale Energy Cost Data

ERCOT wholesale energy markets dispatch at 5-minute intervals, with an associated Locational Marginal Price (LMP) for each 5-minute interval. Austin Energy's wholesale energy purchases are paid at the Austin Energy Load Zone (LZ_AEN), which is made up of multiple LMPs in the Austin Energy territory. In this study, LZ_AEN prices were used. The market settles at 15-minute Settlement Price Points (SPP), with each SPP the average of three LMPs and Operating Reserve Demand Curve (ORDC) price adders. ORDC adders reflect the value of available reserves. LMPs were used as an input to simulations, with DERs responding to 5-minute market price signals, and SPP were used to calculate net wholesale energy costs over time.

2020 Real Time Energy price projections were generated by scaling historical 2016 price data to match projected monthly average 2020 prices. Two 2020 time series price projection datasets were generated using two different 2020 average monthly price forecasts. UPLAN¹'s base price forecast provides a single projected price for each month. To create 2020 projected time series pricing based on the UPLAN forecast, monthly scaling values were created by taking the difference between the UPLAN 2020 average price forecast for each month and the corresponding month's observed average real-time energy price. The historical 2016 time series data was then shifted by this scaling value, so the resulting dataset follows the 2016 price profile while the monthly averages match the UPLAN 2020 forecast.

The Over-The-Counter (OTC) Global Exchange Market Rates provide separate 2020 monthly average real-time energy price forecasts for peak and off-peak hours. ERCOT defines peak times as times between Monday-Friday from 7am to 10pm (except for holidays), Hour Ending (HE), so running from 6:01am to 10:00pm. All other times are considered off-peak. Holidays are always considered off-peak even if they fall on a weekday. To create 2020 projected time series pricing based on the OTC forecast, monthly peak scaling values were created by taking the difference between the OTC 2020 average price forecast for each month and the corresponding month's observed average real-time energy price during peak times and monthly off-peak scaling values were created in the same method using off-peak OTC monthly forecasts and observed 2016 average monthly off-peak prices. 2016 time series data was then shifted by the monthly peak scaling values during peak hours and the monthly off-peak scaling values during off-peak hours.

2.4.2.2 Transmission System Cost Data

The cost of the transmission system is allocated to each distribution utility by a system known as 4-Coincident Peak (4CP). The 4CP are the 15-minute intervals of highest or peak demand on the ERCOT system in each of four summer months: June, July, August, and September. The ERCOT 4CP load is the sum of all Distribution System Providers (DSP) 4CP load, divided by four. The DSP 4CP load is the prior year average of 4CP demand, coincident with the ERCOT 4CP peaks.

Each Transmission Service Provider (TSP) reports to ERCOT the Transmission Cost of Service (TCOS), based on invested capital and operating costs. TSPs may choose whether to file an updated TCOS each year with the Texas Public Utility Commission (PUC). Austin Energy last filed in 2018, at a rate of 1.18 \$/kW. The sum of all transmission rates includes investments from TSPs from different years. Each Distribution Service Provider (DSP) is then billed according to their share of the total ERCOT TCOS, as determined by their share of the 4CP load.

Austin Energy is both a TSP and DSP. Austin Energy's wholesale transmission rate that it charges to DSPs is given by

$$T_rate = \frac{TCOS (\$)}{ERCOT_4CP(kW)}$$

and Austin Energy's TCOS obligation is given by

¹ See <http://www.energyonline.com/Products/Uplane.aspx>

$$AE\ TCOS = \left[\sum_{ERCOT\ TSPs} T_rates\ (\$/kW) * AE_{4CP}(kW) \right] - \left[AE_T_rate\ (\$/kW) * ERCOT_4CP\ (kW) \right]$$

The value of a 4CP load reduction by the action of a DER on a SHINES circuit can be taken to be

$$Value\ of\ 4CP\ load\ reduction\ in\ 2020 = \frac{2020\ TCOS}{2019\ ERCOT_4CP} = \$60.35/kW_4CP$$

To estimate the value in the model year 2020, the ERCOT 2019 4CP load and 2020 total TCOS are required. Unofficial ERCOT 2019 4CP load is 70,639,250 kW. Using ERCOT’s Transmission Project Information Tracking Tool, planned major investments between 2017 and 2020 were tabulated and given an amortization of 12% over 30 years, then added to the 2017 TCOS. The total TCOS in 2020 is estimated to be \$4.26B.

Table 2-1 lists the present-day and forecasted values required to calculate the 4CP cost, and the value of a reduction in 4CP load. The control application that reduces the effective 4CP load will also reduce this cost.

Table 2-1: Present and Forecasted 2020 Values for 4CP Calculations

Variable	Present	Forecast
ERCOT 4CP Load	67,690 MW (2016)	70,639 MW (2019)
Austin Energy 4CP Load	2,570 MW (2016)	2,568 MW (2019)
Total TCOS	\$3.5 Billion (2017)	\$4.3 Billion (2020)
Sum ERCOT Transmission Rates	52.9 \$/kW (Mixed Year)	60.4 \$/kW (Mixed Year) *
Austin Energy’s TCOS Obligation	\$57.5 Million (2017)	\$78.9 Million (2020)

*As the economic modeling was conducted and relied on multi-year forecasting, the following evaluations represent approximations by which Austin Energy can now compare to more recent figures. For example in Table 2-1, the Forecast Sum ERCOT Transmission Rates, or postage stamp rate, is listed at \$60.4/kW yet Austin Energy knows the 2019 postage stamp rate is \$54.57/kW and it is unlikely to increase to the estimated rate by 2020. This discrepancy would impact the final AE TCOS obligation, which was forecasted at \$78.9 million. Walking through the equations and using the updated postage stamp rate of \$54.57/kW, AE TCOS = (\$54.57 * 2,568,000 kW) - (\$1.18/kW * 70,639,000 kW) = \$57 million. Thus, the economic modeling predicted an obligation \$22 million higher, reducing the value of 4CP peak load reduction. For reference, the preliminary load forecast (2021), is estimating AE TCOS obligations of about \$72.2 million (\$159 million owed and \$86.8 million received) for the use of its Transmission system. This would place the original \$78.9 million only \$7 million over, potentially increasing the value of 4CP load reduction in the future.

2.4.2.3 Ancillary Services Cost Data

As a Balancing Authority, ERCOT is responsible for provision of Ancillary Services (AS) that maintain reliable and secure operation of the bulk system. ERCOT has four AS: Responsive and Non-Spinning Reserves, Regulation Up, and Regulation Down. ERCOT allocates AS obligations to each Qualified Scheduling Entity (QSE), or generation provider, based on its Load Serving Entity (LSE), Load Ratio Shares (LRSs), allocated per AS and on an hourly basis. In practice, Austin Energy typically self-supplies much of its AS obligation. Any AS obligation not self-supplied must be procured in the hourly AS markets. For the System LCOE calculation, the Market Clearing Prices (MCP) were used as a proxy for the cost of providing AS. Self-supplying tends to be less expensive, but detailed data for the cost of self-supplying is not easily obtainable, so the MCPs were used as a stand-in. The SHINES circuit’s AS obligation was found by scaling the Austin Energy AS obligation by the SHINES circuit’s fraction of the Austin Energy load at hourly intervals over the calendar-year period. The total cost of AS per hour is computed by multiplying the MCP of each service by the SHINES circuit’s obligation and then the total AS cost is computed by integrating the costs over the calendar year.

2.4.2.4 ERCOT Administrative Cost Data

ERCOT charged all QSEs an administrative fee to fund the operation of the electric grid and market. The fee was \$0.555 per MWh in 2016 and remains unchanged in the 2018 budget. ERCOT anticipates maintaining a flat administrative

service fee through 2020. This fee is charged to all QSEs based on their MWh consumption. Control applications and DER deployments that reduces the MWh consumed inside the SHINES boundary will reduce this cost.

2.4.2.5 ERCOT Uplift Charges

ERCOT periodically must issue uplift charges to QSEs, for make-whole payments to correct for shortfalls in Reliability Unit Commitment (RUC) capacity-short charges. Uplift charges can vary, quite a bit depending on what occurs in the market and by month as well. There are also more uplift charge types than RUC however for the purposes of this methodology, only this was considered for approximate example. Austin Energy uses approximately \$3.6M per year in an internal model used to set risk metrics around Power Supply Adjustment (PSA), which was approximately \$200k shy of 2016 charges of \$3.8M but very shy of the 2017 charges of \$6.3M. Austin Energy’s PSA recovers fuel for generation, transportation, renewable purchase power agreements, purchase power to serve retail customers, ERCOT fees, hedging and the balance from the previous period. In essence, the PSA recovers net wholesale market costs, as a combination of wholesale costs as well as revenues. For the System LCOE calculation, the uplift charges of the two years were averaged, and scaled by the fraction of the Austin Energy load on the SHINES circuits. As the load within the SHINES system boundary is decreased, this cost will also decrease.

2.4.3 DER Cost Data

To calculate the impact of new DER assets, the cost of the DER assets and the amount of energy that they generate is required. The cost data was obtained from project partners responsible for the various DER systems and from NREL’s System Advisor Model for additional solar PV generation. To calculate the impact of holistic controls, a detailed implementation of the DER management platform control strategies was modeled and applied to the model of the system with the addition of new DERs. Austin Energy’s debt service is used in the cost of service model and is the only relevant cost of capital in the baseline model. In this project, the same cost of capital is used for all assets, including DERs. This approximation introduces some error because the cost of a DER depends on the owner; the cost of capital is lower for a municipal utility as compared to a homeowner or a commercial business. This error is small compared to the total cost of the system and is highly unlikely to change the conclusions. If it is determined to be necessary at a later step, the varying cost of capital of different types of owners could be applied as a post-processing adjustment. Detailed DER cost data can be found in the Appendix, A. *Fielded DER Costs* and B. *DER Costs*.

2.5 System Boundary

Over the course of the Austin SHINES project, Austin Energy and partners have installed more than 3MW of distributed storage, smart solar inverters, a DER control platform, and other enabling technologies utilizing customer and utility locations and multiple aggregation models. These resources are integrated and optimized at the utility level using a variety of management strategies. Figure 2-4 shows the assets that comprise the Austin SHINES system, with the assets added as part of the SHINES project indicated with a star.

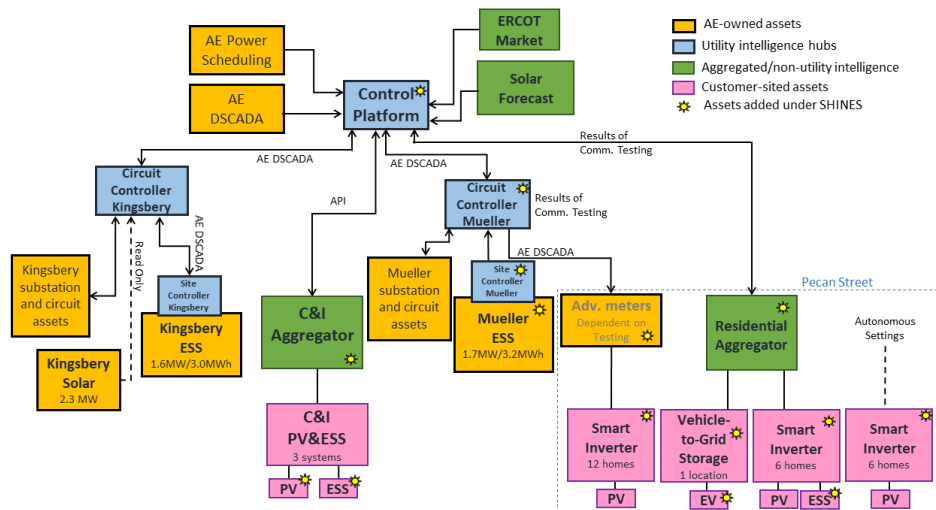

Figure 2-4 Austin SHINES System Assets

All SHINES assets are hosted on five distribution feeders, which are supplied by two different substations. The SHINES assets include:

- Utility-scale ESS connected at the feeder head of a Kingsbery circuit (KB-1), 1.5MW/3.0MWh
- Utility-scale ESS connected at a mid-point on a Mueller circuit (MU-3), 1.5MW/3.2 MWh
- Community solar PV project connected at the feeder head of a Kingsbery circuit (KB-1), 2.6 MW
- Commercial aggregated ESS, two on the Kingsbery circuit (KB-3), one at 18kW / 36kWh and one at 72kW / 144 kWh, and one on the Mueller circuit (MU-2), 72kW / 144 kWh, with existing solar (in total 300kW+)
- Residential aggregated ESS, 10 kWh each, at six homes on the Mueller circuit (MU-3), each with existing solar
- Residential solar, utility controlled with smart inverters, at twelve homes on a Mueller circuit (MU-3)
- Residential solar, autonomously controlled with smart inverters, at six homes on a Mueller circuit (MU-3)

For the calculation of the Austin SHINES System LCOE, the system boundary is defined as two non-contiguous islands, one encompassing the Kingsbery distribution feeders 1 and 3, and one encompassing the Mueller distribution feeders 2 and 3, for the following reasons:

- Kingsbery distribution feeders 1 and 3 share a step-down transformer and Load Tap Changer (LTC), as do the Mueller distribution feeders 2 and 3. Voltage support and power factor control on distribution feeders that share a voltage regulation device are highly interdependent and should be modeled jointly.
- The tap actions of the substation LTC are affected by patterns of distributed generation and reactive power flows inside the boundaries. To model that interdependency, the LTC should be inside the system boundary.
- The boundary encompasses all SHINES DER assets.
- The power flow and voltage are metered at the substation in more temporal granularity than anywhere else in the system, making the calculation of energy entering and leaving the system straightforward.

Defining the boundary in this way, rather than a boundary that encompasses the entire Austin Energy system, entails two approximations.

- The larger Austin Energy system and ERCOT system are assumed to be insensitive to the flows of energy and services through the boundary. In actuality, the actions of assets inside the system boundary, such as increased levels of solar PV generation or reactive power support from smart inverters, will affect the wider system, but these effects are small compared to the stiffness of the larger system.
- The Austin Energy rate case is used as a source of data for the capital and O&M costs of the distribution system infrastructure. Austin Energy pools costs across its service territory in calculating the rate case, so the cost of the distribution system infrastructure inside the boundary is assumed to be consistent with Austin Energy's average costs.

2.6 System Timescales

The characteristic time scales of elements in the system that must be captured in the System LCOE calculation are indicated conceptually in Figure 2-5 (below the time axis), along with the applications that are implemented by the DER management solution in the Austin SHINES project (above the time axis). There are relevant phenomena at the time scale of seconds, including variation in load, variation in solar PV generation, and response time of smart inverters. The voltage support application extends to this time scale. There are several applications at the 5 to 15-minute time scale, including congestion management, demand charge reduction, and the bulk market functions of LMP variance and peak load reduction. The ERCOT wholesale markets dispatch at 5-minute intervals and settle at 15-minute intervals. There are both diurnal and seasonal patterns in load and solar PV generation, as well as in wholesale energy market prices. Finally, asset lifetimes are measured over one to four decades.

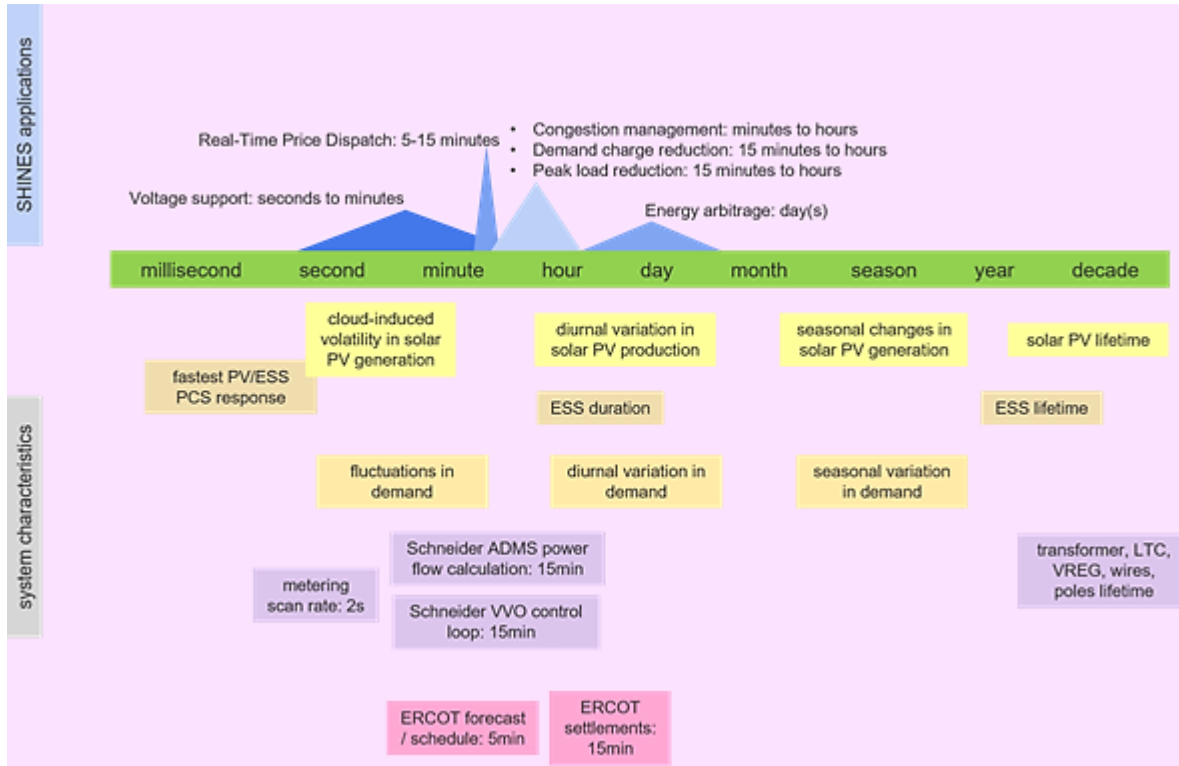

Figure 2-5 Austin SHINES System Time Scales and application Time Scales

To provide an optimizing controls strategy, the System LCOE metric must address all these time scales, but it is not practical to run a time-series simulation with power flow at 1-second time resolution over a multi-year duration. Key tradeoffs in controls optimization can be captured by taking the following approach:

- The core models span a calendar year duration with 5-minute resolution. This allows all control applications that involve real power to be modeled simultaneously to capture tradeoffs and optimize value to the system.
- Separately, shorter-duration and higher-resolution models are used to study the voltage support application, capturing tradeoffs between use of DER assets for real power generation and reactive power support. The time resolution of simulations focused on voltage support is 1 minute, due to the 1-minute granularity of solar and load data available from Pecan Street.
- To address potential future scenarios such as changes to ERCOT wholesale market policies, changes to ERCOT wholesale market prices, changes to DER asset costs, etc., the calendar-year duration calculation is carried out under a variety of different scenarios and assumptions.

The average System LCOE over a calendar year was calculated as the metric for controls optimization and the purpose of benchmarking the cost of the Austin SHINES system at project milestones and stage gates.

Asset lifetimes may be affected by the DER configuration and controls approach. This is captured by calculating adjustments to the baseline cost. For example, some secondary service transformers may experience thermal overload under high-solar PV penetration scenarios. This thermal overload stresses the insulating materials of the transformer and shortens the asset lifetime. The additional cost of a replacement must occur earlier than in the baseline scenario is calculated, and applied as an adjustment to the baseline costs.

2.7 Circuit Model

The distribution system simulation and analysis tool GridLAB-D is used to carry out detailed circuit analysis. GridLAB-D is a flexible, object-oriented simulation environment with an open source code base that allows users to add new objects or features. For the Austin SHINES project, most of the objects and control modes that are required have been implemented, but in some cases new control objects were created or new control functionality was added.

2.7.1 Base Network Model

The base of all circuit analysis is the network model, which describes the physical and control objects inside the system boundary and the ways that they interact with each other and in response to external stimuli. Austin Energy uses Milsoft’s WindMil software for systems engineering work. The network model was exported into GridLAB-D format using WindMil’s built-in export options. As described in Section 2.5, the Austin SHINES system consists of two non-contiguous electrical islands, one encompassing three feeders that are fed from a common substation bus in the Kingsbery (KB) substation, and another encompassing two feeders that are fed from a common substation bus in the Mueller (MU) substation.

The KB system has an 138kV/12.47kV Delta-Grounded Wye step-down transformer at the substation with a Load Tap Changer (LTC). Voltage regulation is accomplished by the LTC and by seven switched capacitors acting under local control. The MU system similarly has an 138kV/12.47kV Delta-Grounded Wye step-down transformer at the substation with LTC, but no switching capacitors on the feeder or other electromechanical voltage control devices. Austin Energy is in the process of implementing a Volt-Var VVO feature as part of its ADMS deployment, but VVO has not yet been implemented on the KB and MU feeders and will not be during the SHINES deployment period. The network models contain topology and impedance for these devices as well as all cables, service transformers, and service drops to customers, listed in Table 2-2.

Table 2-2: Network Topology Models

Variable	Kingsbery (KB)	Mueller (MU)
Lines	2,556	1,115
Transformers	731	241
Customer Meters	4,017	1,768

The electric infrastructure in KB is primarily overhead; whereas in MU all lines are underground. GridLAB-D models and power flow solution support full three-phase unbalanced analysis.

2.7.2 Time-series Data: Solar

Time-series solar data was obtained from project partner Pecan Street, which has historical meter data of residential solar installations on the MU feeders. Real power generation from 159 residential customers at 1-minute intervals over the calendar year 2016 was supplied with excellent data quality for most of the meters. Figure 2-6 shows a five-day window of Pecan Street solar PV data. Each curve in color represents a single meter and is normalized based on the maximum value. The black line is the aggregated (total) solar generation in the baseline MU system. Three different PV generation patterns can be identified:

- 3/27 a mostly sunny day with intermittent cloud coverage
- 3/28 a sunny day with almost no cloud coverage,
- 3/29 a mostly cloudy day

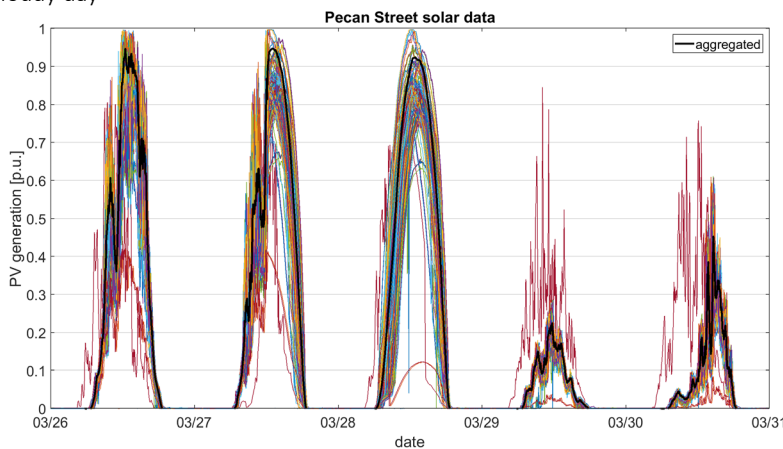

Figure 2-6 A sample of Pecan Street solar generation time-series data

Pecan Street data was used to generate solar time-series for customers without available solar meter data. For each customer, 1 out of 159 Pecan Street solar generation time-series (which was normalized based on maximum generation) was picked randomly. The normalized time-series was then scaled according to the capacity of solar PV installed at the customer meter and skewed slightly in time (to mimic clouds passing overhead, and to avoid unrealistically coordinated solar generation fluctuations from geographically dispersed sites).

To analyze the system at a different solar penetration level (most importantly, 25% penetration by energy), solar generation must be added to service points which previously did not have any solar installation. For these service points, a similar approach was taken to generate time-series solar data.

For use in the aggregated energy balance calculation carried out for the preliminary System LCOE calculation, the aggregated solar generation curve (solid black line) was used.

2.7.3 Time-series data: Load

The accuracy of the circuit model requires capturing the characteristics of meter-level energy consumption at a high temporal resolution. Historical meter data, which is typically used for billing purposes, can provide a source of high-resolution meter-level information.

There are two major challenges to using meter data, especially at distribution level. First, typically a distribution circuit supplies many customers, and direct use of granular meter data can significantly increase the volume of input data to the point that is beyond the capabilities of the software or hardware used for modeling purposes. Second, distribution-level meter data tends to have poor data quality compared to feeder-head data, mainly because utilities may use different metering systems and routines for different types of customers. Therefore, meter data is normally a combination of numerous records in very different formats. Also, any upgrades in the existing metering system or routine may change the way the energy consumption is being recorded. This may lead to missing or irregular historical meter data.

To integrate the meter data into the circuit model, this data needs to be preprocessed, cleaned up and, if voluminous, reduced in dimension.

2.7.3.1 Feeder-head Data

Load data measured at the feeder head, at the substation bus, reflects the aggregate behavior of customers on the feeder. Feeder-head data can be useful for synthesizing and reconstructing the meter data when such data is unavailable or has poor data quality. Feeder-head data has better data quality compared to meter data. However, it may still have periods where data is missing due to issues with the meter, or the way the data was transmitted or archived. Operations and maintenance may require switching load to be fed from an alternate source and result in the feeder operating in off-normal conditions; these periods are excluded from analysis.

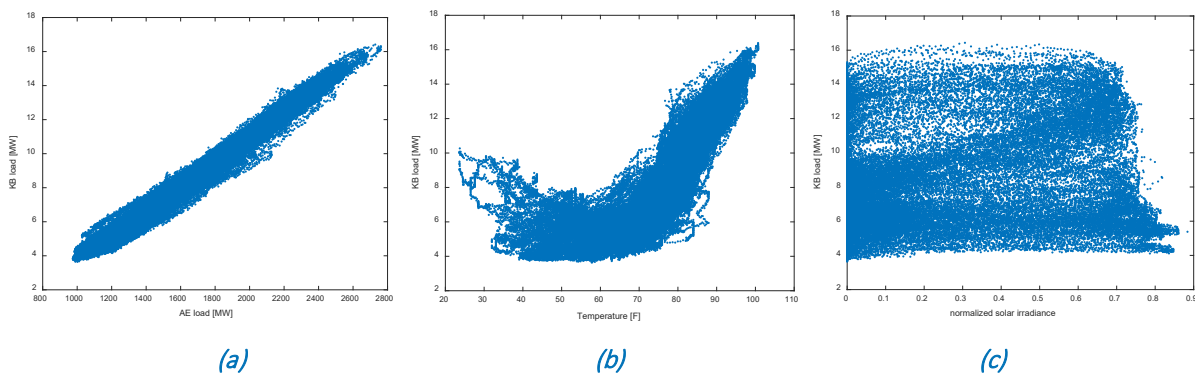

Figure 2-7 Correlation between the KB feeder-head demand and independent variables a) Austin Energy total load, b) temperature, and c) solar irradiance

Regression analysis was used to reconstruct time periods of missing or excluded feeder-head data. Other information was available about the variables that impact feeder-head data, such as load data from super- or sub- systems (which may have similar pattern as the feeder-head data), ambient temperature, solar irradiance, etc. Figure 2-7 shows the

scatter plots of KB feeder-head demand vs those variables. A strong correlation between the KB feeder-head demand and Austin Energy total demand was observed in Figure 2-7 (a). Also, heating ventilation and air conditioning (HVAC) load makes up a significant portion of the KB feeder-head demand as there was a distinct temperature dependence in the scatter plot shown in Figure 2-7 (b). The correlation between the feeder-head demand and between solar irradiance was very weak, visible in Figure 2-7 (c) but including it in the regression model improved the estimations.

The following multivariate quadratic regression model was used to estimate the feeder-head data, with Austin Energy total load, ambient temperature, and solar irradiance being the independent variables:

$$y_t^{fh} = \beta_0 + \beta_1 x_t^{ae} + \beta_2 (x_t^{ae})^2 + \beta_3 x_t^\theta + \beta_4 (x_t^\theta)^2 + \beta_5 x_t^\gamma + \beta_6 (x_t^\gamma)^2$$

where y_t^{fh} is the feeder-head real power demand at time t , x_t^{ae} is the Austin Energy total load at time t , x_t^θ is the ambient temperature and x_t^γ is the solar irradiance at time t . β_i ($i = 0, 1, \dots, 6$) are regression parameters to be determined. The Austin Energy total load data was available with perfect data quality over the calendar year from Austin Energy's historian. The ambient temperature was recorded at roughly hourly (irregular) intervals at the Austin airport with no significant data gaps over the calendar year, and linearly interpolated to 5-minute intervals. Solar irradiance data was not available directly, so 1-minute solar generation of a sample Pecan Street customer (in kW) was normalized and used as a proxy. Solar generation (at unity power factor, in a system with minimal inverter clipping) closely follows solar irradiance, and the time-dependence is essentially the same. This equation is written for every timestamp. Since the independent variables are of very different scale, to create a well-behaved regression model, these variables are normalized based on their maximum value.

Figure 2-8 shows a portion of load data measured at Austin Energy's MU feeder head from 03/07/2016 to 03/14/2016. The original data has a resolution of 1 minute. In Figure 2-8, the data is down-sampled to 5 minutes to match the year-long simulation timescale of 5 minutes. The solid blue line represents the actual data received from Austin Energy. The solid red line shows the estimated data using regression. To evaluate the goodness of fit, the coefficient of determination or R-squared is used. R-squared is defined as:

$$r^{sq} = 1 - \frac{\sum_t (\hat{y}_t - \bar{y})^2}{\sum_t (y_t - \bar{y})^2}$$

where \hat{y}_t is the actual data at time t , y_t is the estimated data at time t and \bar{y} is the mean (average) of the actual data. An r^{sq} close to 1 indicates a good fit whereas an r^{sq} close to zero indicates a poor fit.

$r^{sq} = 0.9805$ for MU feeder head-data and 0.9858 for KB feeder head-data.

Also, for the week of 03/14, when there is no actual data available, the regression model can reconstruct the missing patch.

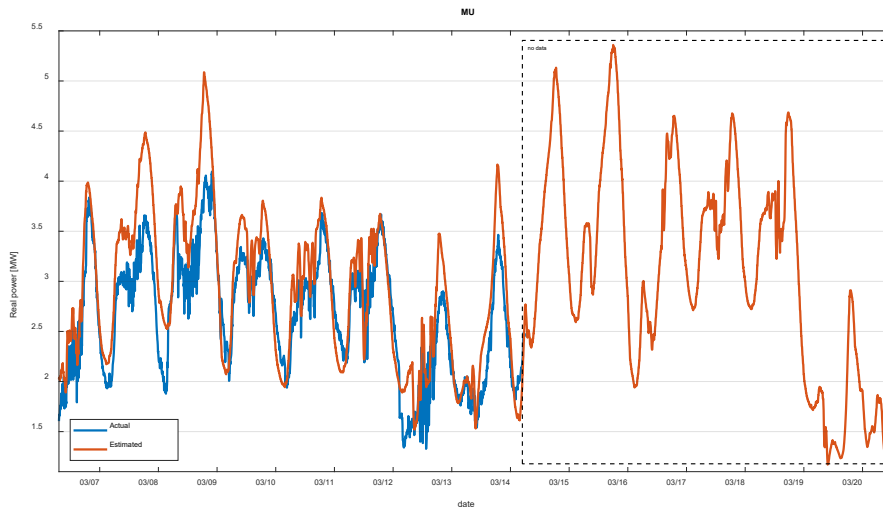

Figure 2-8 MU feeder-head data from 03/07/2016 to 03/20/2016; solid blue line: actual data, solid red line: estimated data

2.7.3.2 Austin Energy Meter Data

There are 1,768 service point IDs (SPIDs) on MU and 4,017 on KB, each associated with a customer meter. In 2016 Austin Energy transitioned to a new metering system, and there has been a migration from the old metering system (known as Lodestar) to a new metering system (known as Command Center Load Profiler CCLP).

Lodestar data contains daily reads of year-to-date (cumulative) energy consumption of each SPID. Figure 2-9 shows the 2016 Lodestar data for a sample SPID on MU. For this particular SPID, Lodestar data is only available through to the end of March, and migration to the new metering system happened at beginning of April.

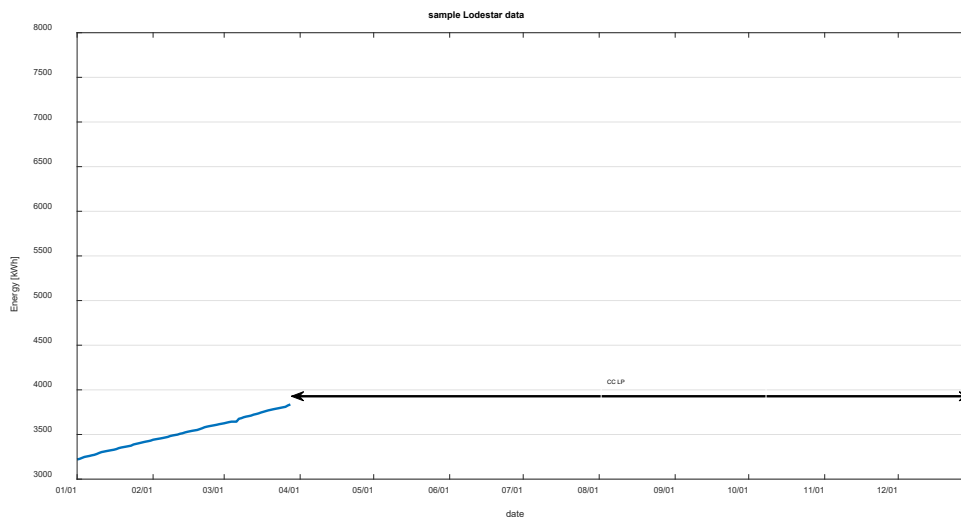

Figure 2-9 Sample Lodestar data; data is available until the end of 3/16; transition to CC LP happened in 4/16.

CC LP data contains 15-min interval energy consumption of SPIDs. Figure 2-10 shows the 2016 CC LP data for the same service point ID as in Figure 2-9. The CC LP consumption data is made available in April (after the migration from the Lodestar system took place). Compared to Lodestar, CC LP data has a higher temporal resolution, and is not cumulative.

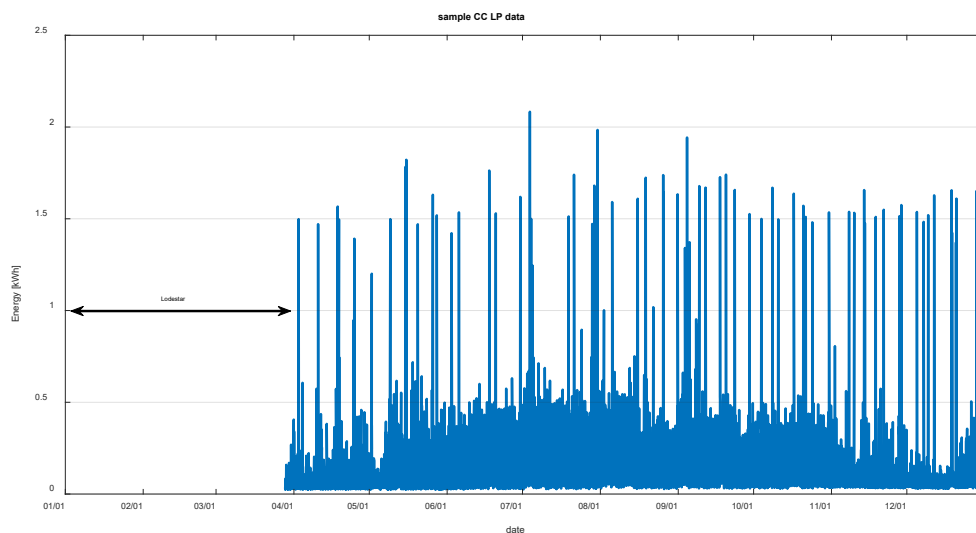

Figure 2-10 Sample CC LP data; data is available beginning 4/16

To represent the meter data for the full calendar year for an SPID, the data from Lodestar and CC LP needs to be concatenated. This is accomplished by calculating the daily cumulative energy consumption from the CC LP data and combining it with Lodestar data.

Figure 2-11 shows how the two sets are concatenated for the aforementioned SPID. Although the daily cumulative meter data is obtained for the full calendar year of 2016, it lacks the required resolution for time-series modeling. Section 2.7.3.3 describes how CC LP and Loadstar data was used to create time-series meter data

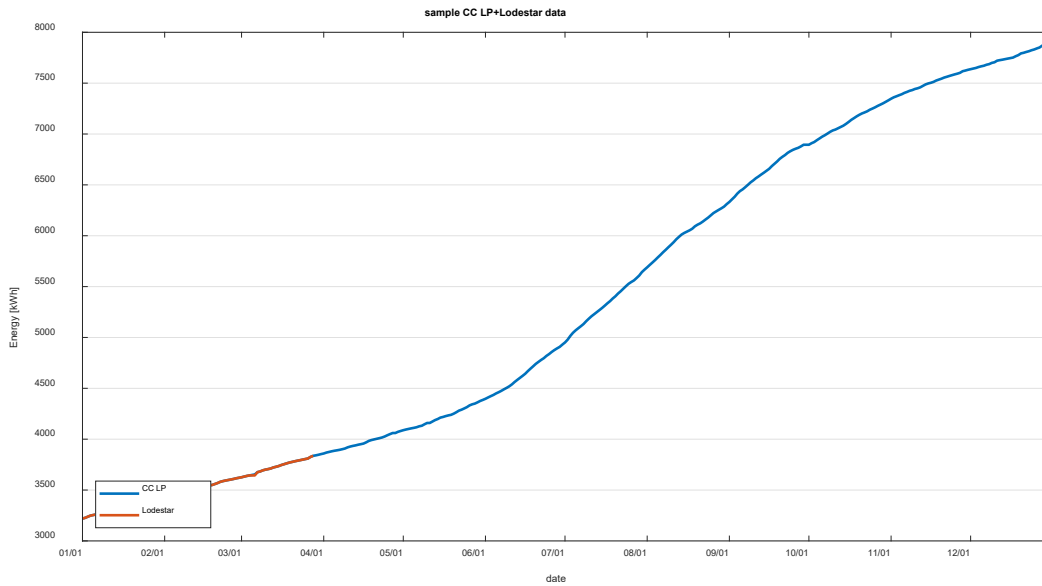

Figure 2-11 Concatenation of Lodestar (red) and CC LP (blue) data in the hourly cumulative consumption format

Pecan Street Data

In addition to solar PV data, partners at Pecan Street also provided the 1-minute interval load consumption data for the 159 residential customers over the calendar year 2016. Figure 2-12 shows a five-day window of Pecan Street load consumption. In cases where Pecan Street data was available for a customer, it was used directly.

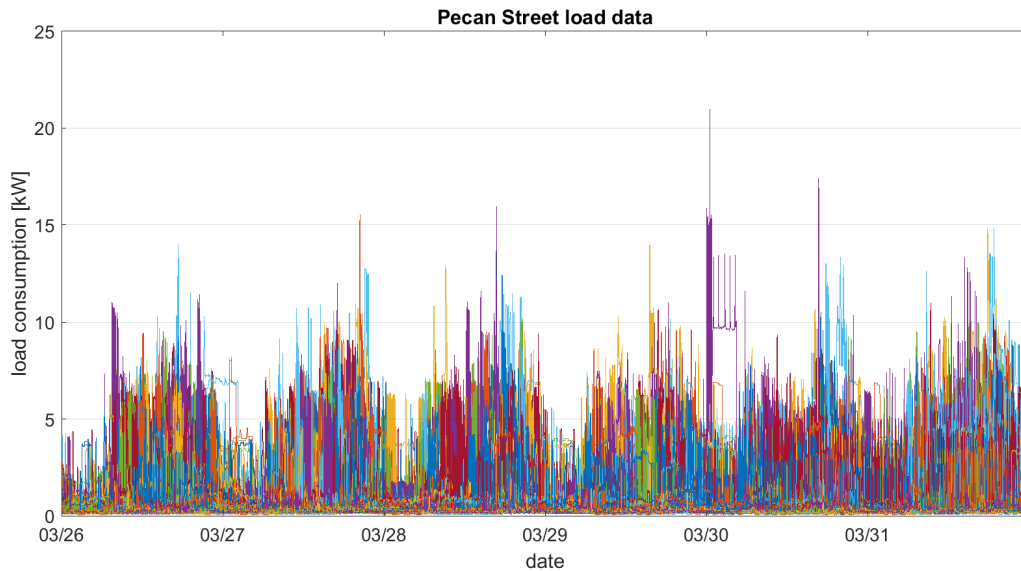

Figure 2-12 A sample of Pecan Street load consumption time-series data

Electric Vehicle Data

Electric Vehicle (EV) data from the following sources is used for modeling and control of EVs in System LCOE calculations. Since enough data from 2016 was not available, data from 2017 and 2018 was used:

- 3 multifamily locations (2016)
- 2 single family locations enrolled in EV360 Time-Of-Use Pilot program (2017)
- 30 single family locations provided by Pecan Street (2018)

Figure 2-13 shows sample time-series data for each category.

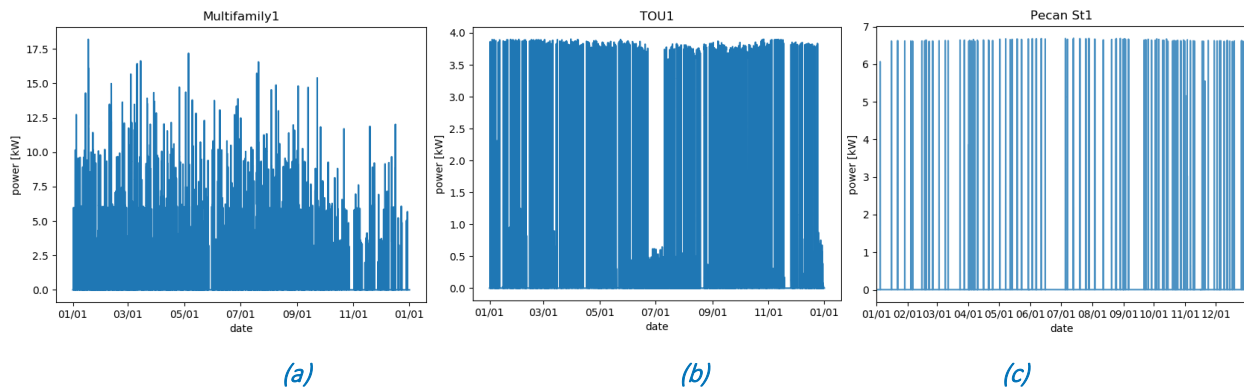

Figure 2-13 EV data samples; (a) multifamily (b) EV360 TOU (c) Pecan Street

Data from public and non-residential chargers was not included in the analysis.

2.7.3.3 **Time-series Meter Data**

The following algorithm is used to generate times-series data to be used in the GridLAB-D simulations:

1. Use 15-minute interval CC LP data when available
2. For the portion of the year when data is stored on Lodestar and only daily reads are available, use normalized feeder-head data and scale it based on the daily energy consumption from Lodestar data.

The above algorithm directly uses CC LP data when it is available. For the portion of the year when the Lodestar metering system was in use and granular meter data is unavailable, the algorithm takes the feeder-head data, normalizes and down-samples it (to the resolution of CC LP data which is 15 min), and then scales it such that the daily energy consumption calculated from this time-series data matches that of Lodestar data.

For debugging and testing purposes, a simplified time-series load data set was constructed that uses an identical aggregated feeder-head load shape for each customer, scaled to be equivalent to their total consumption over the course of the calendar year.

2.7.3.4 **Integration of Time-series Data**

Although assigning an individual time-series to each SPID contributes to preserving the characteristics of the actual distribution circuit, software limitations do not allow for such implementation. Assigning a unique time-series input file to each SPID slows the simulation to impractical levels.

The solution adopted to decrease the dimensions of input data is clustering. There are numerous clustering algorithms among which k-means has been widely used in various applications including distribution circuit customer clustering [1] [2]. Based on the similarities between the datasets, this algorithm partitions the datasets presented to it into several clusters. Each cluster has a centroid which is the average of datasets inside the cluster. The distance between each dataset to the centroid of its cluster is an indication of how similar that dataset is to the rest of the cluster members. A dataset with minimal distance to the centroid is a good candidate to represent that cluster.

Applying k-means clustering to the time-series meter data of KB and MU, the customers can be partitioned into 11 and 10 clusters respectively. In addition to closeness to the centroid of each cluster, another requirement imposed is

that the cluster representative must have at least 70% of its data directly come from CC LP data (and not the synthesized data). This condition ensures that the cluster representative has the quality of original meter data.

Figure 2-14 depicts the contents of a cluster. The colorful lines represent the individual cluster members while the black line shows the cluster representative. The consumption patterns of members inside a cluster are very similar to each other and to that of the cluster representative.

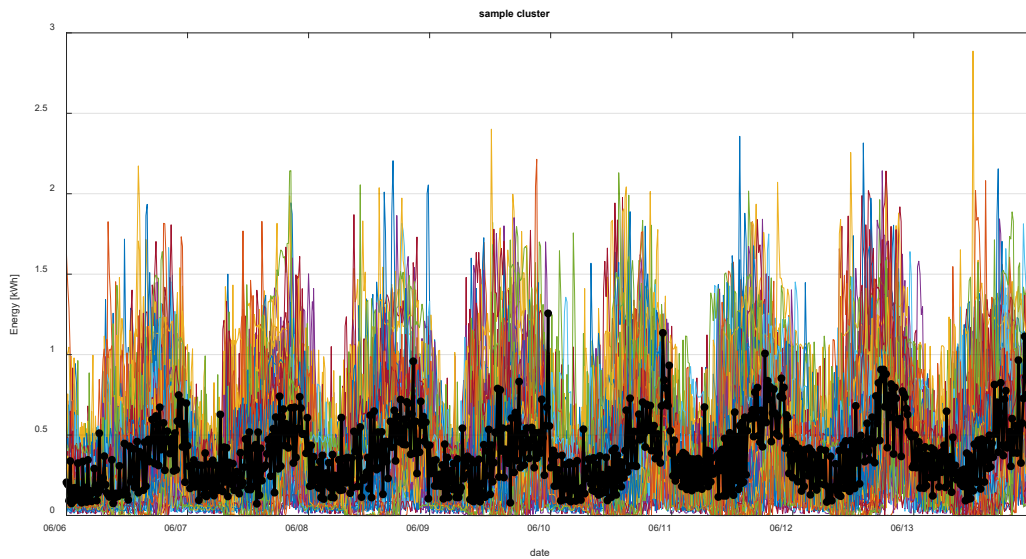

Figure 2-14 Sample of a data cluster; colorful lines: cluster members, black line: cluster representative

Section 3 Baseline System

The baseline circuit analysis has the primary purpose of characterizing the system and its performance (power quality, quality of service, solar penetration level, etc.) prior to the addition of SHINES assets so that differences between baseline and high-DER penetration scenarios can be characterized. This section discusses the baseline circuit analysis results and the baseline System LCOE results.

3.1 System Characterization and Key Performance Indicators

Simulation of the base circuit model fed with time-series input data makes the high-resolution system characterization possible. Time-series graphs of measurements taken at major locations of the feeders, combined with key performance indicators are used to describe the overall characteristics of the system.

The measurements are:

- Total real power demand, aggregated load recorded at SPIDs
- Total solar power generation, aggregated real power output of inverters
- System voltage heatmaps during shoulder and peak months

The key performance indicators related to voltage control include:

- Maintained within ANSI C84.1 limits (+/- 5% of nominal voltage)

3.1.1 Kingsbery (KB)

Figure 3-1 shows the total real power demand of KB feeder. The peak power demand was 16.9MW which occurred on August 12, 2016. The load was strongly-summer peaking due to air conditioning load, with an average winter daytime high of 6.5MW and an average summer daytime high of 10.0MW.

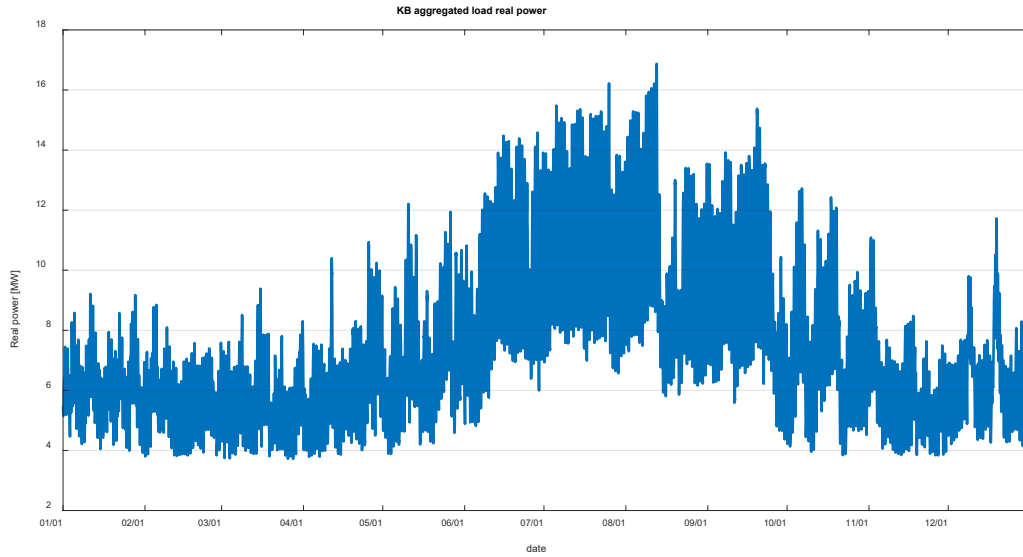

Figure 3-1 KB aggregated real power demand

Figure 3-2 shows the total solar power generation of KB. Peak solar generation of 0.44MW occurred on March 24, 2016. The baseline solar penetration level by energy was 1.1%. Peak solar penetration by power occurred on March 26, 2016 (around 11:45:00 AM), with 8.6% of power supplied by solar.

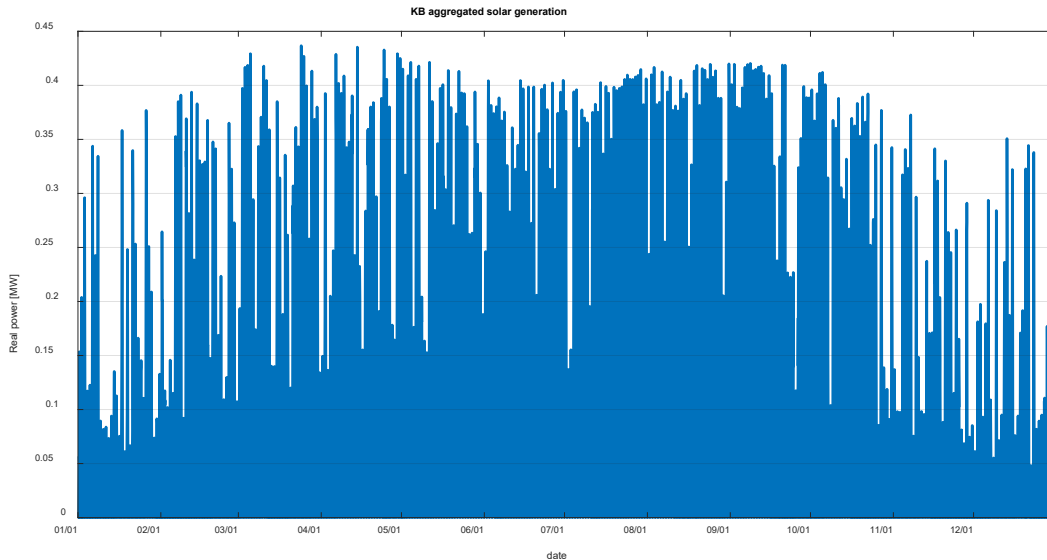

Figure 3-2 KB aggregated solar power generation

Figure 3-3 compares the total load, total solar generation and the net load (total load minus solar generation) of KB. As the level of solar penetration was only 1.1% by energy, the total and net loads had insignificant differences. No back-feeding happened in the system as the generated solar power was considered small.

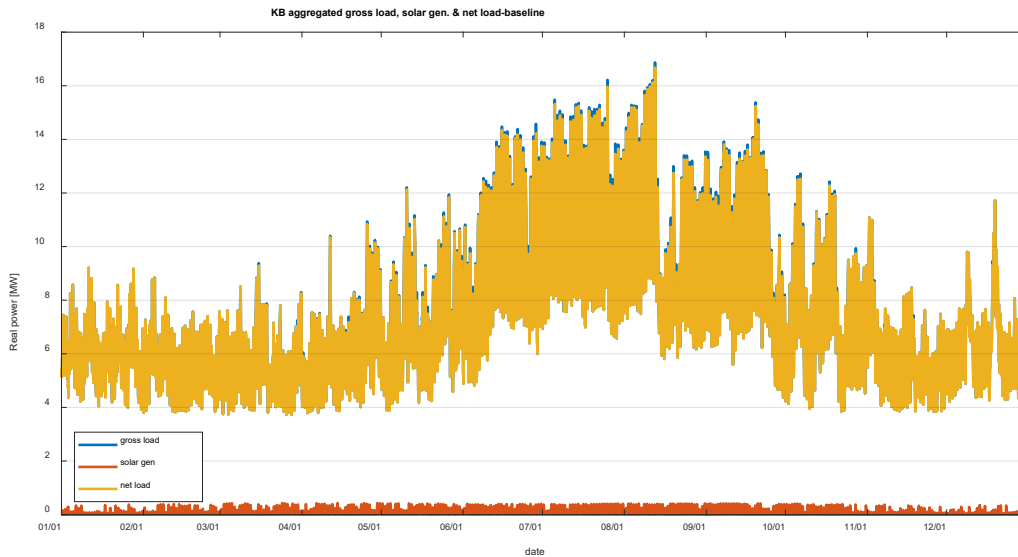

Figure 3-3 Comparison between gross load, solar generation and net load for KB

Figure 3-4 magnifies a one-week section of Figure 3-3 in March 2016, when the system was lightly loaded. The daily consumption pattern had two peaks, with the first peak happening in the morning (near 6 AM) and the second peak happening in the evening (near 6 PM). The total (gross) and net loads were identical except when solar generation existed. There was a strong correlation between consumption, temperature and time of the day.

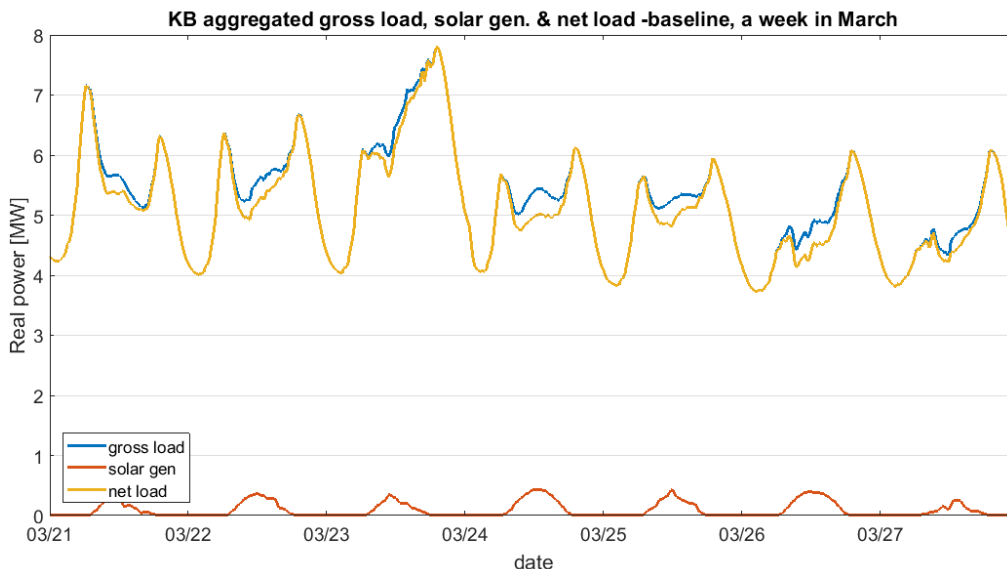

Figure 3-4 Comparison between gross load, solar generation and net load for KB; a sample week in March (shoulder season)

Figure 3-5 shows the heatmap of per unit nodal voltages (averaged over three phases) for KB-2 at 12:00 PM on March 24, 2016. Voltages near ANSI C84.1 high limit (1.05 p.u.) are shown with a red/brown hue while voltages near the ANSI C84.1 low limit (0.95 p.u.) tend to have a blue hue. As Figure 3-4 shows, KB was lightly loaded on this day. Most nodal voltages fell within the range of 1 p.u. to 1.03 p.u. No over- or under- voltage was observed in this case.

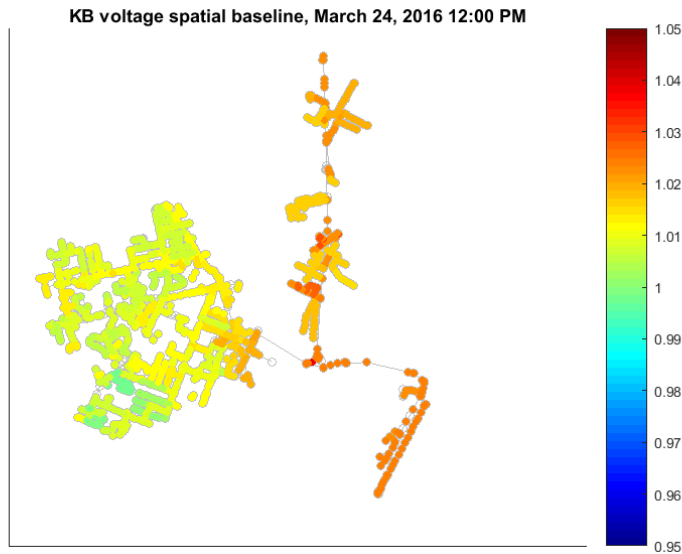

Figure 3-5 Voltage heatmap of KB at 12:00 PM on March 24, 2016, baseline solar

Figure 3-6 magnifies a one-week section of Figure 3-3 in June 2016, when the system was heavily loaded. The daily consumption pattern peaked only once, near 6 PM. Again, the total (gross) and net loads were identical except when solar generation existed. There was a strong correlation between consumption, temperature and time of the day.

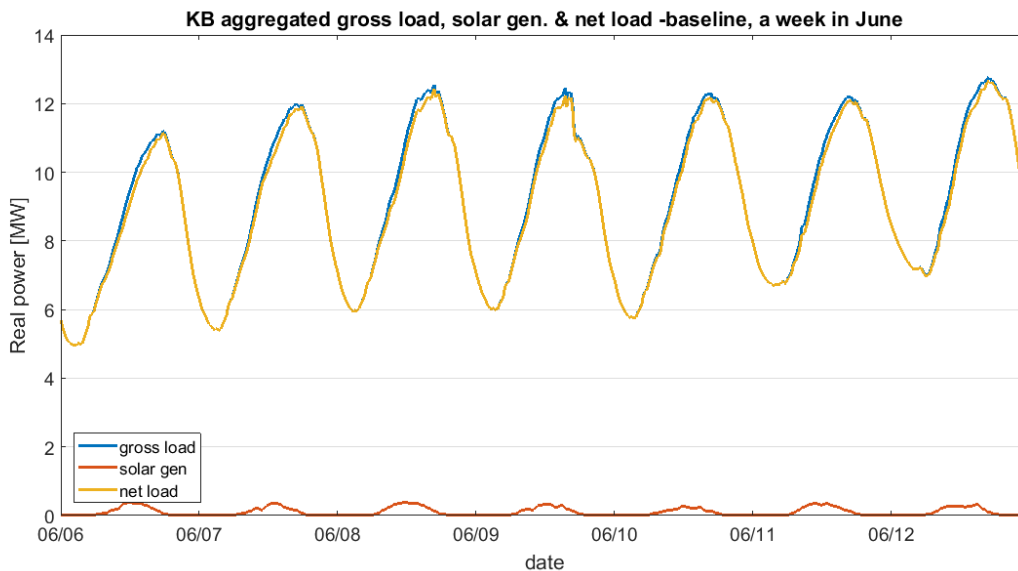

Figure 3-6 Comparison between gross load, solar generation and net load for KB; a sample week in June (peak season)

Figure 3-7 shows the heatmap of per unit nodal voltages for KB at 12:00 PM on June 9, 2016. As Figure 3-6 shows, KB was heavily loaded on this day. Since KB feeders were equipped with switched capacitor banks, under heavy-loading conditions these banks switched on to increase the voltage. Capacitor banks switching operations together with the tap changing operations affected the voltage profile throughout the network. Compared to MU, where there was no voltage regulating device except for LTC at the substation, changes in voltage were not as proportionate to loading conditions and solar generation in KB.

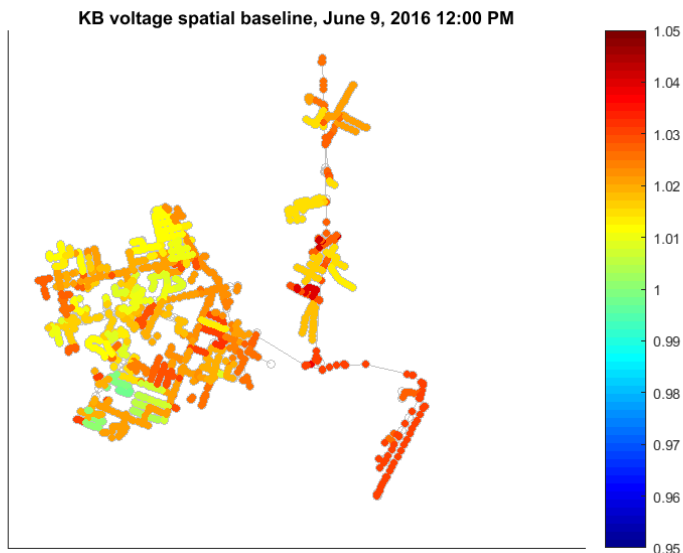

Figure 3-7 Voltage heatmap of KB at 12:00 PM on June 9, 2016, baseline solar

In general, the one-year analysis of system nodal voltages in the baseline KB system did not show any violations of ANSI C84.1 limits.

3.1.2 Mueller (MU)

Figure 3-8 shows the total real power demand of MU feeder. The peak power demand was 8.9MW, which happened on August 12, 2016. Like KB, the load was strongly-summer peaking due to air conditioning load, with an average winter daytime high of 3.4MW and an average summer daytime high of 5.6MW.

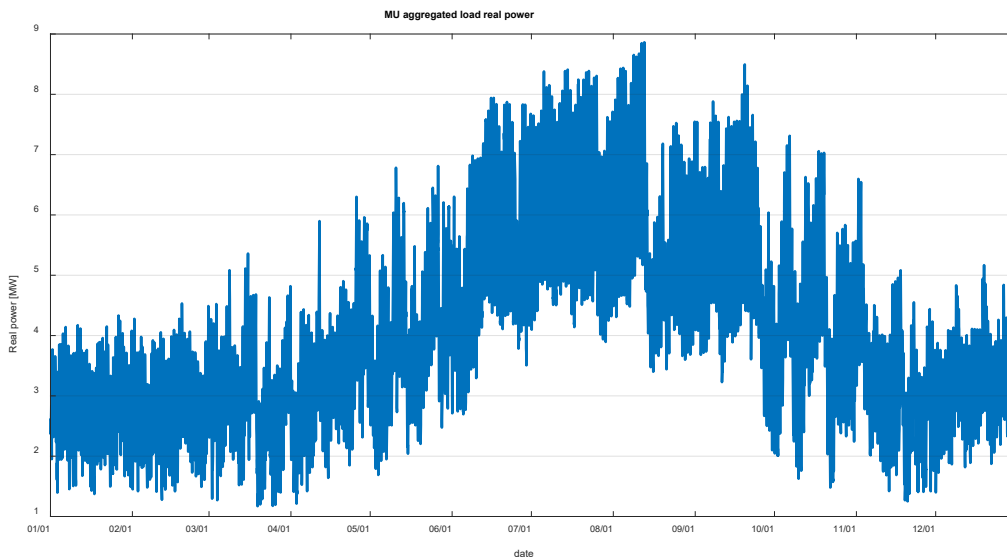

Figure 3-8 MU aggregated real power demand

Figure 3-9 shows the total solar power generation of MU. Peak solar generation was 1.3MW that happened on March 24, 2016. The baseline solar penetration level by energy was 5.3%. Peak solar penetration by power during 2016 occurred on March 26, 2016 (at noon), with 69.9% of power supplied by solar.

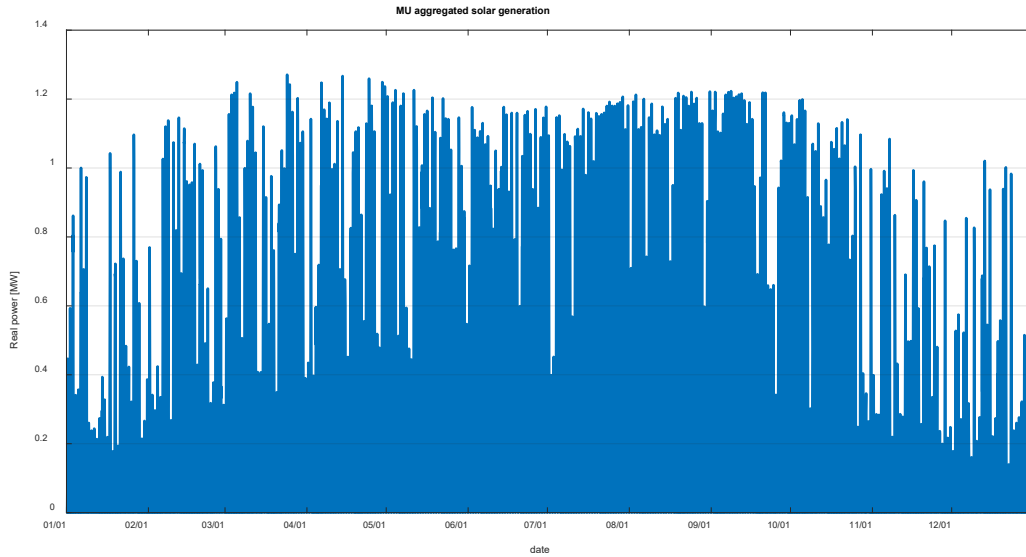

Figure 3-9 MU aggregated solar power generation

Figure 3-10 compares the total load, total solar generation and the net load (total load minus solar generation) of MU. As the level of solar penetration was more significant for MU compared to KB, the total and net loads of MU had more visible differences. Still, no back-feeding happened in the system as the generated solar power was small.

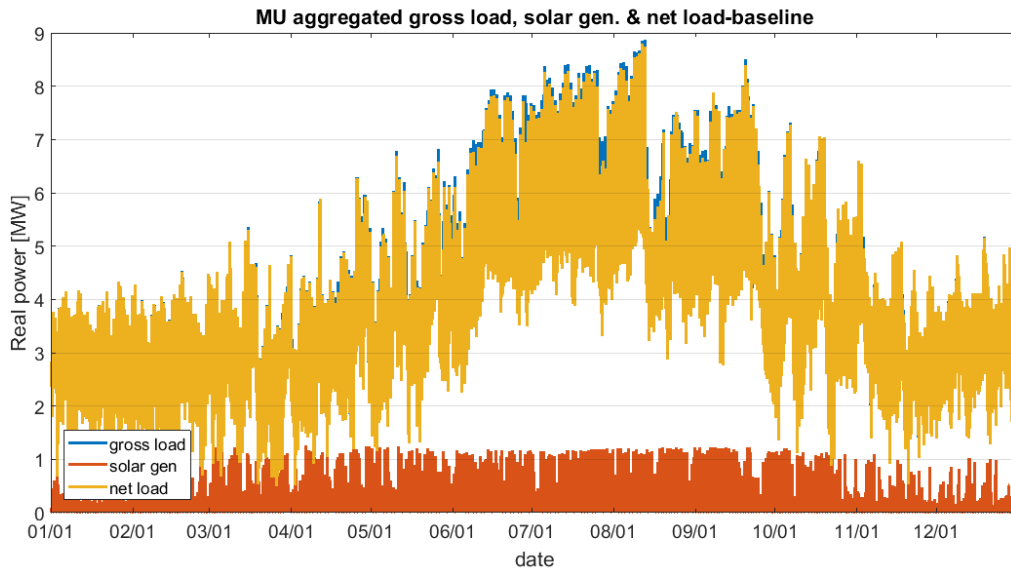

Figure 3-10 Comparison between gross load, solar generation and net load for MU

Figure 3-11 magnifies a one-week section of Figure 3-10 in March 2016, when the system was lightly loaded. The daily consumption pattern had two peaks, with the first peak happening in the AM (near 6 AM) and the second peak happening in the PM (near 6 PM). The total (gross) and net loads were identical except when solar generation existed. There was a strong correlation between consumption, temperature and time of the day.

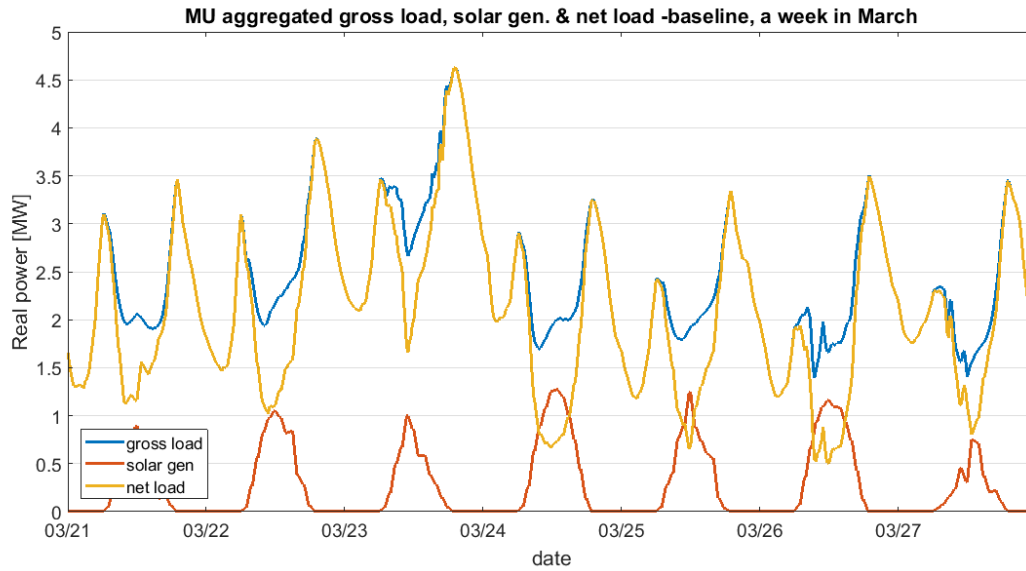

Figure 3-11 Comparison between gross load, solar generation and net load for MU; a sample week in March (shoulder season)

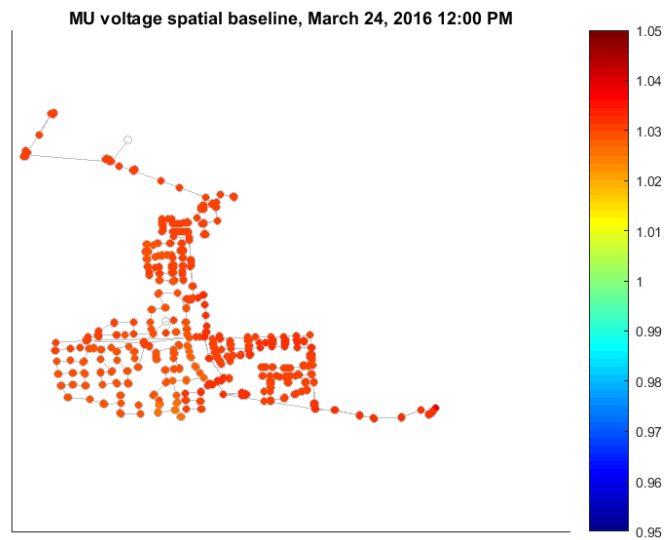

Figure 3-12 Voltage heatmap of MU at 12:00 PM on March 24, 2016, baseline solar

Figure 3-12 shows the heatmap of per unit nodal voltages for MU at 12:00 PM on March 24, 2016. MU was lightly loaded on this day, and most nodal voltages were close to the upper limit of 1.05 p.u. No over- or under- voltage was observed in this case.

Figure 3-13 magnifies a one-week section of Figure 3-10 in June 2016, when the system was heavily loaded. The daily consumption pattern peaked only once, near 6 PM. Again, the total (gross) and net loads were identical except when solar generation existed. There was a strong correlation between consumption, temperature and time of the day.

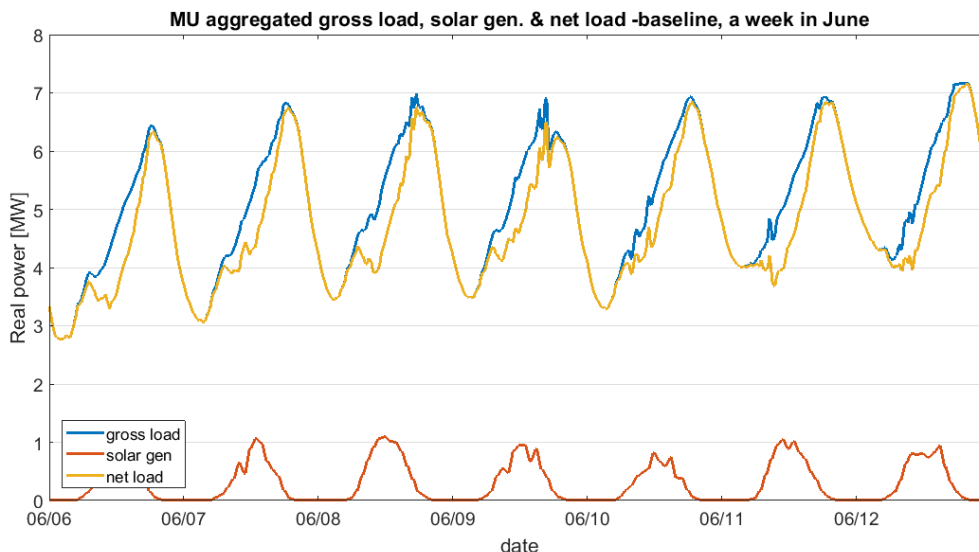

Figure 3-13 Comparison between gross load, solar generation and net load for MU; a sample week in June (peak season)

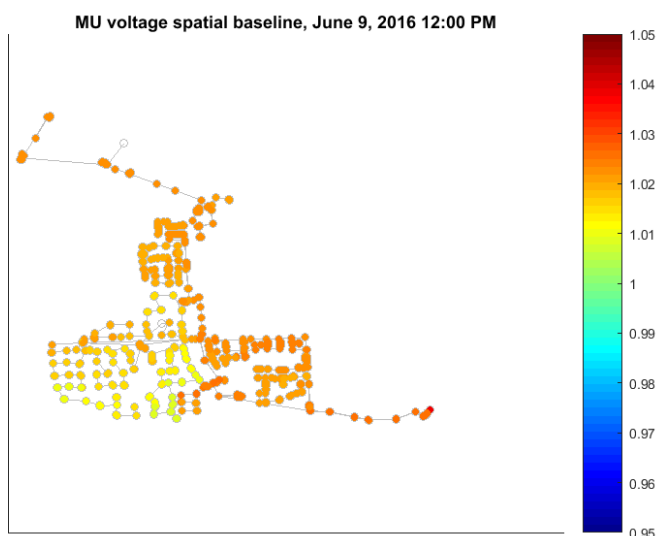

Figure 3-14 Voltage heatmap of MU at 12:00 PM on June 9, 2016, baseline solar

Figure 3-14 shows the heatmap of per unit nodal voltages for MU at 12:00 PM on June 9, 2016. As Figure 3-13 shows, MU was heavily loaded on this day. Compared to Figure 3-12, nodal voltages were lower. No over- or under- voltage was observed in this case.

Similar to KB, the one-year analysis of system nodal voltages in the baseline MU system did not show any violations of ANSI C84.1 limits.

3.2 Baseline System LCOE result

The top-level System LCOE results are summarized in Table 3-1 for the KB system and the MU system. The baseline System LCOE is \$0.088/kWh for the KB circuits and \$0.090/kWh for the MU circuits over the course of the calendar year in the md-DER and md-ERCOT cost assumption set, which takes mid-range estimates for all DER costs and all wholesale market prices. This calculation uses the costs of the utility-owned infrastructure as it exists today, the cost of the DERs that exist in the system today, and the cost of the purchase of energy from ERCOT wholesale markets over the course of the calendar year. All costs are on an annualized basis. The capital and operating costs are derived

from the rate case, which produces a yearly cost. The net cost of energy and services imported to the system is integrated over the test year, as is the load served and solar penetration.

Table 3-1: Baseline System LCOE

Scenario description		KB baseline	MU baseline
System LCOE to serve load (\$/kWh)	lo-DER lo-ERCOT	\$0.082	\$0.084
	lo-DER hi-ERCOT	\$0.093	\$0.096
	md-DER md-ERCOT	\$0.088	\$0.090
	hi-DER lo-ERCOT	\$0.082	\$0.084
	hi-DER hi-ERCOT	\$0.093	\$0.096
Annualized capital cost of infrastructure to serve load (\$)	lo	\$3,046,807	\$1,868,189
	md	\$3,046,807	\$1,868,189
	hi	\$3,046,807	\$1,868,189
Annual operating cost of infrastructure to serve load (\$)	lo	\$90,269	\$75,172
	md	\$90,269	\$75,172
	hi	\$90,269	\$75,172
Net annual cost of energy and services imported to system (\$)	lo	\$2,284,101	\$1,309,665
	md	\$2,672,511	\$1,526,426
	hi	\$3,060,921	\$1,743,188
Sum of load served within system over test year (kWh)		6.64E+07	3.85E+07
Solar PV penetration by energy over test year (%)		1.0%	5.3%

The System LCOE to serve load is similar between the two circuits, at \$0.088/kWh in KB and \$0.090/kWh in MU. Because almost all the energy consumed is purchased from the ERCOT wholesale energy market in the base case, rather than generated locally, the System LCOE is sensitive to ERCOT costs, but not very sensitive to DER costs. The System LCOE equation is in Figure 2-2. The computed value of each term is listed in Table 3-1 for the md-DER md-ERCOT cost.

Section 4 System with 25% Solar Penetration

This section discusses the impact of increasing the solar penetration in the circuit to 25%.

4.1 Solar PV generation scenarios

The baseline penetration of solar (by energy) is 1.1% for KB and 5.3% for MU (see section 3.1). To reach the solar penetration target of 25% solar generation, new solar must be added to both KB and MU.

The following algorithm is used to add new solar to the baseline KB and MU model:

1. Calculate the amount of solar energy required to meet the target
2. Distribute the solar capacity to be added among customers, proportionally to their yearly peak demand
 - Solar capacity to be added to service point ID $i = \left(\frac{P_i^{max}}{\sum_i P_i^{max}} \right) E^{solar}$
 - P_i^{max} : Yearly peak power demand of the i th service point ID
 - E^{solar} solar capacity to be added (by energy)

To achieve the target of 25% solar penetration requires adding 11MW to the KB circuits and 4.9MW to the MU circuits.

4.1.1 25% solar PV generation

Analysis in this report focuses on a future scenario with 25% solar penetration by energy. Future study will consider higher levels of solar penetration.

4.1.1.1 Kingsbery (KB)

Figure 4-1 compares the total load, total solar generation and the net load (total load minus solar generation) of KB when solar penetration was 25% by energy. Compared to Figure 3-3 (baseline) which did not show any back-feeding, Figure 4-1 shows back-feeding happening in shoulder seasons. Maximum back-feeding of -3.91MW happened at 11:45 AM 25-Mar-2016

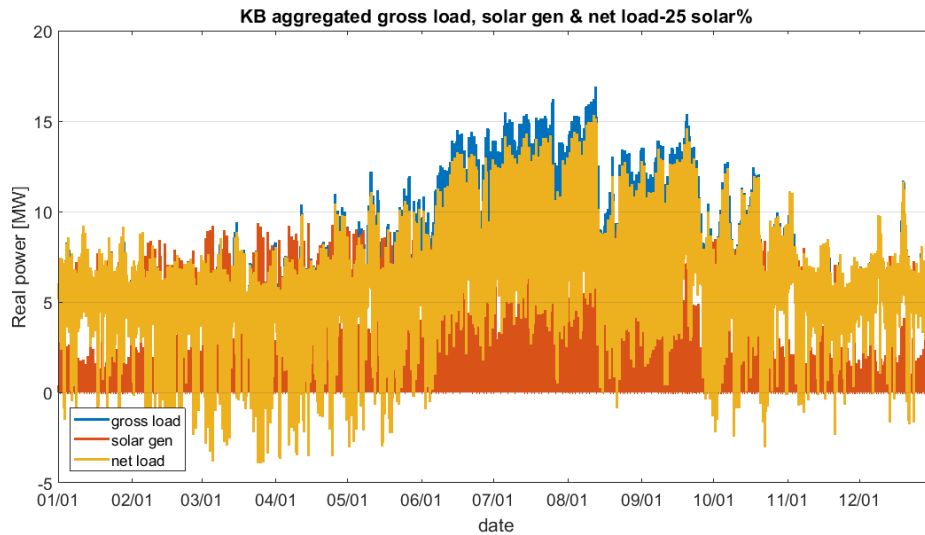

Figure 4-1 Comparison between gross load, solar generation and net load for KB at 25% solar penetration

Figure 4-2 magnifies a one-week section of Figure 4-1 in March 2016, when the system was lightly loaded. Compared to Figure 3-4 (baseline), which did not show any back-feeding, in Figure 4-2 back-feeding happened every day in this week. Maximum daily back-feeding occurred around noon, when solar generation is the highest.

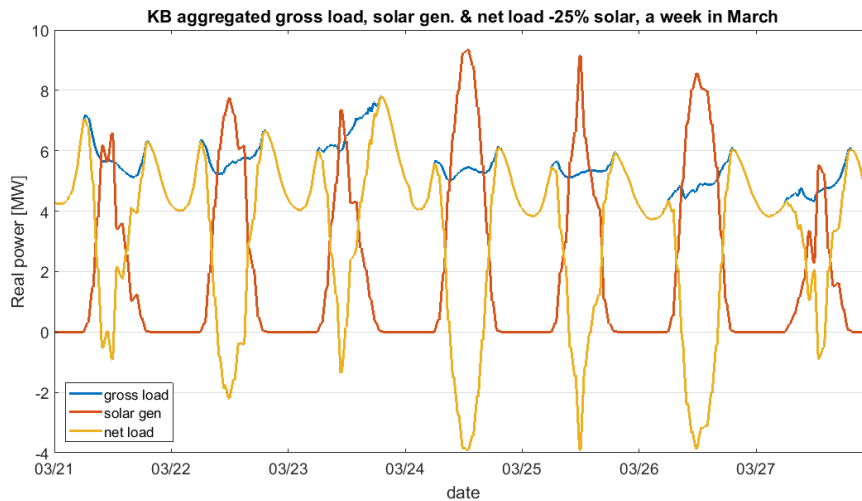

Figure 4-2 Comparison between gross load, solar generation and net load for KB at 25% solar penetration; a sample week in March (shoulder season)

Figure 4-3 shows the spatial map of per unit nodal voltages for KB at 12:00 PM on March 24, 2016. Compared to Figure 3-5 (baseline), there was an increase in voltage. Although voltages tended to be higher than the baseline case; no overvoltage was observed in this case.

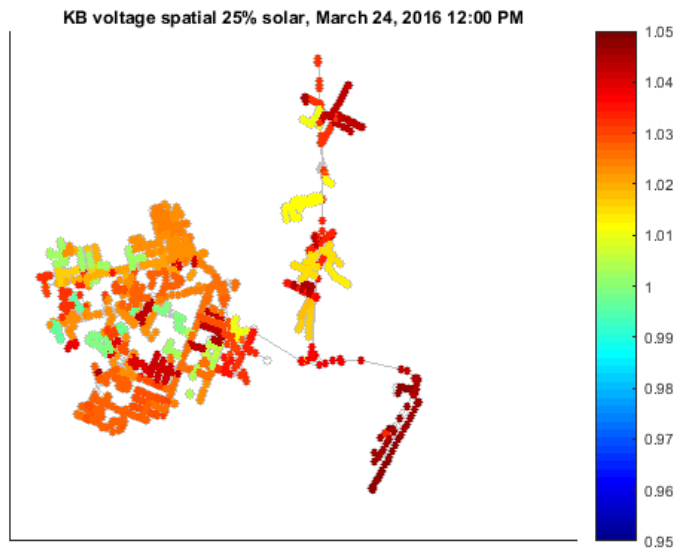

Figure 4-3 Heatmap of KB at 12:00 PM on March 24, 2016, 25% solar penetration

Figure 4-4 magnifies a one-week section of Figure 4-1 in June 2016, when the system was heavily loaded. Compared to Figure 3-6, in this case, local consumption of solar generation caused load reduction. Like the baseline, no back-feeding happened in this week.

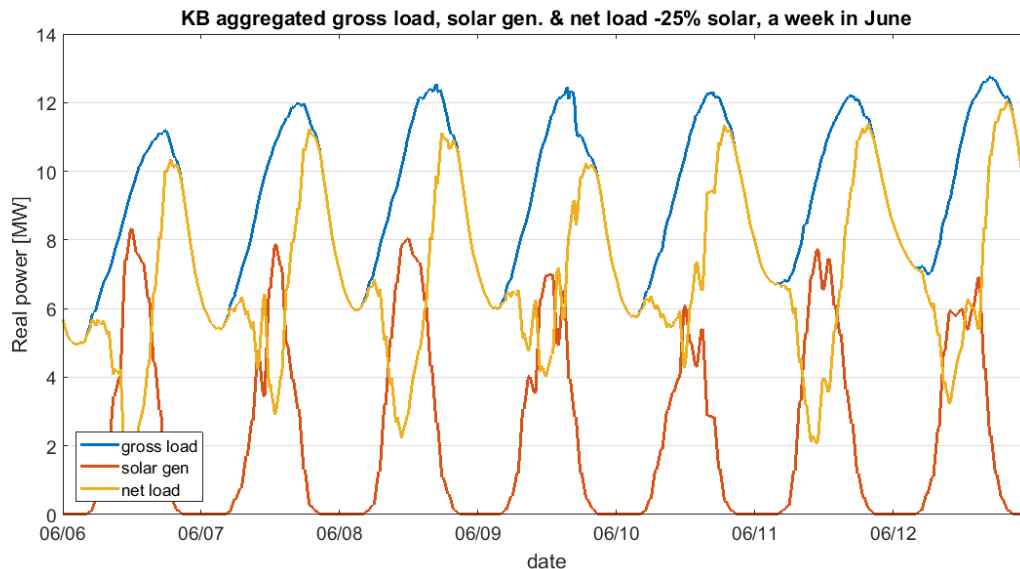

Figure 4-4 Comparison between gross load, solar generation and net load for KB at 25% solar penetration; a sample week in June (peak season)

Figure 4-5 shows the heatmap of per unit nodal voltages for KB at 12:00 PM on June 9, 2016. Compared to Figure 3-7, voltage decreased in some parts of the network and increased in the other parts which was due to the interaction of voltage regulating devices. Overvoltage could be observed in a cluster of nodes (shown in black), a condition which was not observed in Figure 3-7. This suggested at higher penetration voltage control would become more complicated. The analysis for KB with 25% assumed no change in the settings of voltage regulating devices (substation

LTC and switched capacitors). A solution to alleviate the overvoltage is to modify the settings of such devices. A VVO scheme can be used to achieve the desired settings for voltage regulating devices.

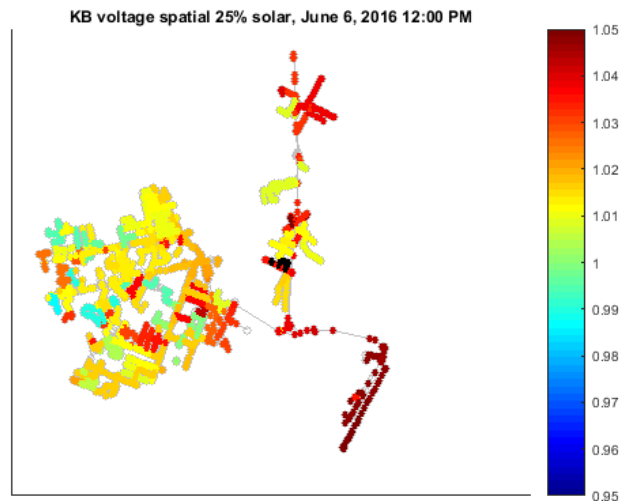

Figure 4-5 Voltage heatmap of KB at 12:00 PM on June 9, 2016; 25% solar penetration

4.1.1.2 Mueller (MU)

Figure 4-6 compares the total load, total solar generation and the net load (total load minus solar generation) of MU when solar penetration was 25% by energy. Compared to Figure 3-10 (baseline) which did not show any back-feeding, Figure 4-6 shows back-feeding happening in shoulder seasons. Maximum back-feeding of -2.97MW happened at 11:45:00 24-Mar-2016.

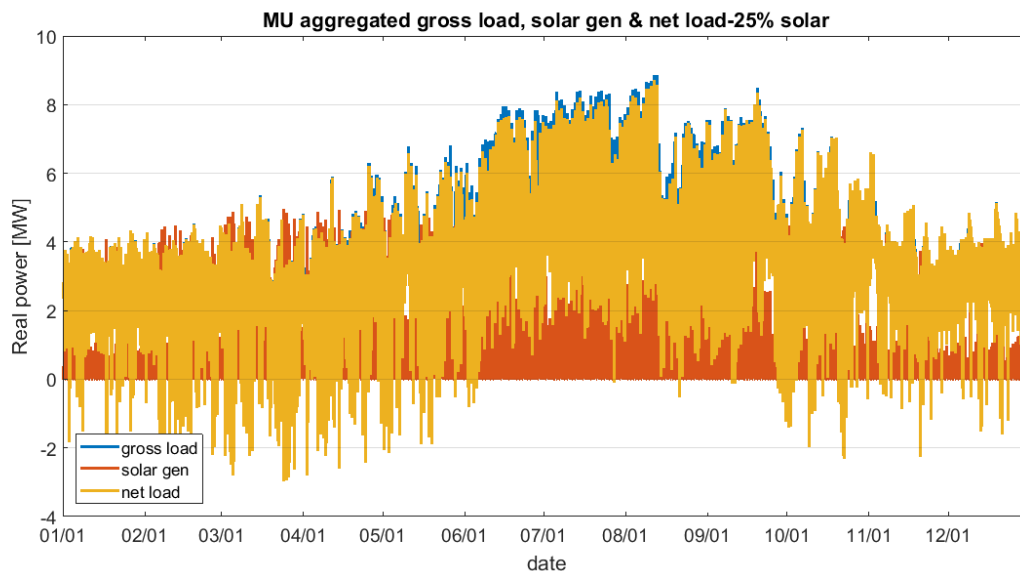

Figure 4-6 Comparison between gross load, solar generation and net load for MU at 25% solar penetration

Figure 4-7 magnifies a one-week section of Figure 4-6 in March 2016, when the system was lightly loaded. Compared to Figure 3-11 (baseline), which did not show any back-feeding, in Figure 4-7 back-feeding was happening every day in this week. Maximum daily back-feeding occurred around noon, when solar generation was the highest.

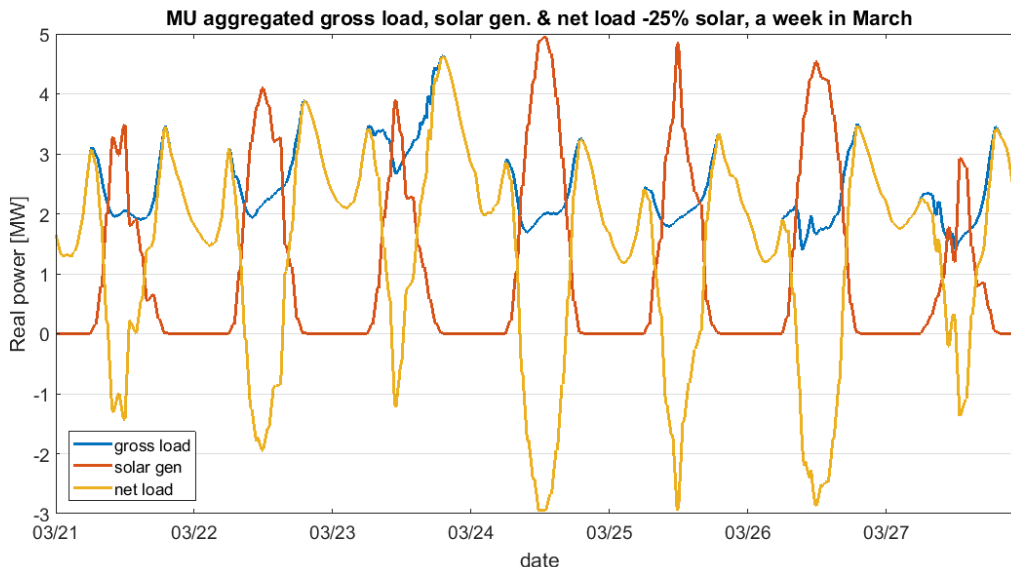

Figure 4-7 Comparison between gross load, solar generation and net load for MU at 25% solar penetration; a sample week in March (shoulder season)

Figure 4-8 shows the spatial map of per unit nodal voltages for the MU system at 12:00 PM on March 24, 2016. The MU system was lightly loaded on this day, and due to high penetration of solar, nodal voltages were higher compared to Figure 3-12. Overvoltage happened in one MU node (shown in black). Like KB, the analysis for the MU system with 25% solar assumed the same LTC settings as the baseline MU system. In the system with 25% solar, nodal voltages are, on average, above 1 p.u. This suggests that adjusting the tap at the substation LTC would alleviate the overvoltage issue.

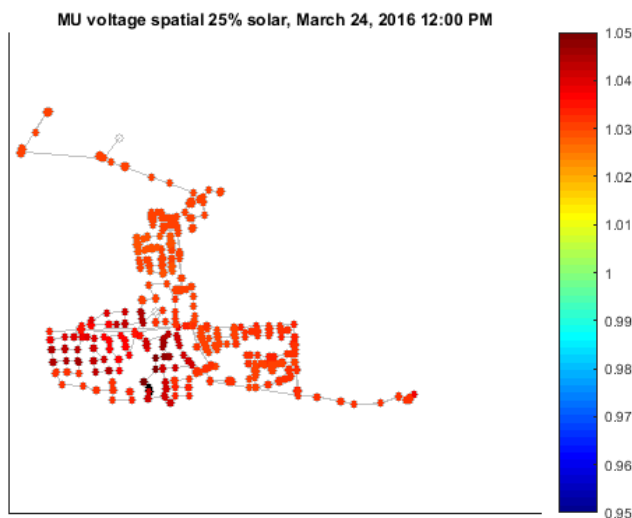

Figure 4-8 Voltage heatmap of MU at 12:00 PM on March 24, 2016; 25% solar penetration

Figure 4-9 magnifies a one-week section of Figure 4-6 in June 2016, when the system was heavily loaded. Compared to Figure 3-13, in this case, local consumption of solar generation caused load reduction. Like the baseline, no back-feeding happened in this week.

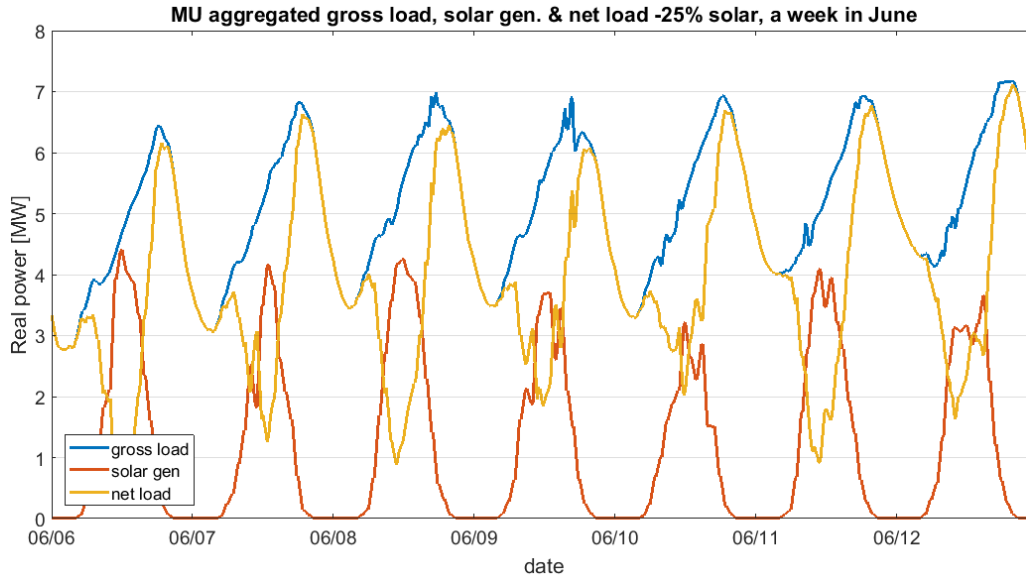

Figure 4-9 Comparison between gross load, solar generation and net load for MU at 25% solar penetration; a sample week in June (peak season)

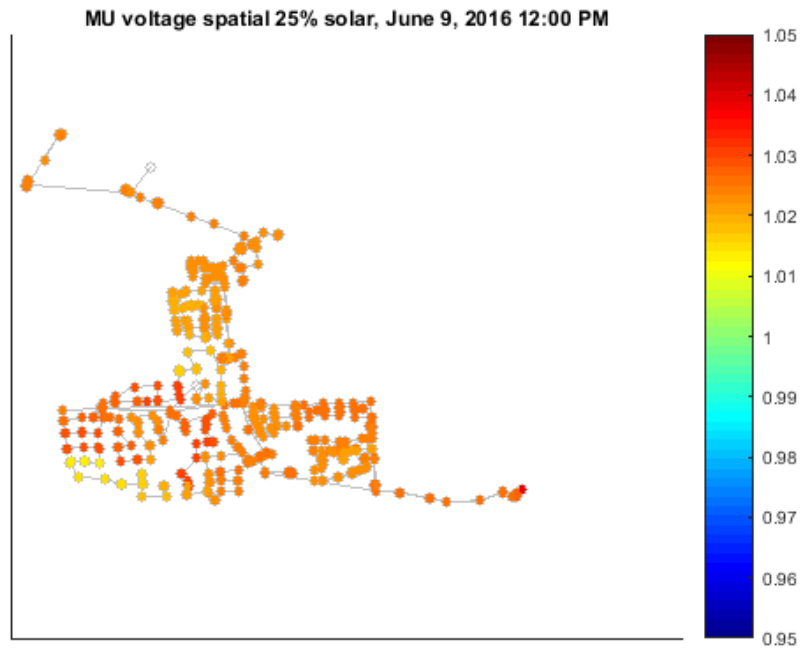

Figure 4-10 Voltage heatmap of MU feeders at 12:00 PM on June 9, 2016; 25% solar penetration

Figure 4-10 showed the heat map of per unit nodal voltages for the MU system at 12:00 PM on June 9, 2016. The system was heavily loaded on this day, and due to high penetration of solar, nodal voltages were slightly higher compared to Figure 3-14, but there was not any overvoltage.

Section 5 Definition of Controls

This Section discusses how the control applications, implemented in the Austin SHINES project, affect the calculation of System LCOE.

5.1 Controls Scenarios

The System LCOE calculations are carried out on multiple scenarios and compared so that the value of holistic controls can be quantified. The baseline scenario is the system as it was during the model year 2016. No SHINES assets are included. Pre-SHINES distributed solar generates at unity power factor, and there are no ESSs. The controls implemented on each DER type for each scenario with added DERs are in Table 5-1.

Three classes of controls are defined for each category of assets:

- No controls
- Autonomous controls
- Holistic controls

In the case of no controls, which is really a case of rudimentary or rigidly scheduled controls, DERs carry out very simple applications. Any changes in the operation of a DER in the no controls scenario are according to preset time schedules intended to maximize the value of the DER, based on such parameters as time-of-use rates, historical load profiles, or energy prices. In the case of autonomous controls, DERs have local intelligence, and respond to real time localized data such as power factor, or substation/building load. But there is no coordination between assets at different locations or of different types. In the case of holistic controls, the assets carry out all the applications enabled by the SHINES control solution and are coordinated and optimized by a fleet manager, DERO.

In addition to the three cases with additional assets, the controls that will be evaluated in the SHINES field demonstration are tabulated for completeness in the italicized column. Due to logistical, financial, or regulatory constraints, some DERs will carry out more rudimentary controls in the field. For example, the La Loma Community Solar project will generate at unity power factor, with no Var support, due to the requirements of the Power Purchase Agreement (PPA). For the purpose of the System LCOE calculation, the controls scenarios that are modeled maintain consistency across DER asset types in the level of controls, and the fielded SHINES controls are not explicitly modeled. Explanations of SHINES Control Applications are further detailed in Section 5.2.

Table 5-1: Controls Scenarios

DER Type	None: Rudimentary, Manual, Scheduled	Autonomous: Local intelligence, but no coordination; "set it and forget it"	Fielded SHINES	Holistic controls: Modeled in addition to Fielded SHINES
<p><i>ESS - Utility</i></p>	<ul style="list-style-type: none"> - Fixed-daily schedule based on historical ERCOT LMP - An average daily LMP profile was calculated based on 2016 historical data. - The average (annual) LMP profile was calculated to be 21.6 \$/MWh - ESS would be discharging for those hours during the day (a 24-hour period) when average daily LMP was greater than average LMP: <ul style="list-style-type: none"> • 10am-9pm ESS Would be charging for those hours during the day (a 24-hour period) when average daily LMP was less than average LMP • 9pm-midnight, midnight-10am <p>Charge/discharge rates (i.e. power) were calculated such that the state-of-charge of the energy storage system at the beginning of the day would be equal to the state-of-charge at the end of the day.</p>	<ul style="list-style-type: none"> - Load following/load shifting calculated based on annual historical substation load profile - Using the 2016 feeder-head load profile, two loading seasons were distinguished, i.e., the summer peak season (June-September) and the shoulder season (January-May and October-December) - For each of the two loading seasons, energy storage charged/discharged based on the following algorithm: <ul style="list-style-type: none"> • charge energy storage if the substation load goes below the charge-on threshold • stop charging energy storage if the substation load goes above the charge-off threshold • start discharging energy storage if the substation load goes above the discharge-on threshold • stop discharging energy storage if the substation load goes below the discharge-off threshold - Charge on/off and discharge on/off thresholds were calculated separately for each loading season using 2016 feeder-head data: <p><u>MU shoulder season</u></p> <ul style="list-style-type: none"> Charge on = 0.5MW Charge off = 1MW Discharge off = 2.5MW Discharge on = 3.3MW <p><u>MU peak season</u></p> <ul style="list-style-type: none"> Charge on = 3MW Charge off = 3.5MW Discharge off = 4MW Discharge on = 5MW <p><u>KB shoulder season</u></p> <ul style="list-style-type: none"> Charge on = 0.5MW Charge off = 1MW Discharge off = 5MW Discharge on = 6MW <p><u>KB peak season</u></p> <ul style="list-style-type: none"> Charge on = 5MW Charge off = 5.5MW Discharge off = 10MW Discharge on = 11MW 	<ul style="list-style-type: none"> - Optimize all value streams together. - DERO runs the following applications: RTPD, PLR, EA, CM, VS 	<ul style="list-style-type: none"> - Optimize all value streams together. - DERO runs the following applications: RTPD, PLR, EA

Pending Approval from U.S. Department of Energy

DER Type	None: Rudimentary, Manual, Scheduled	Autonomous: Local intelligence, but no coordination; "set it and forget it"	Fielded SHINES	Holistic controls: Modeled in addition to Fielded SHINES
<i>PV - Community</i>	Real power generation only No Var support	Real power generation only No Var support	Real power generation only No Var support	Real power generation only No Var support
<i>ESS - Aggregated Residential</i>	<ul style="list-style-type: none"> - Fixed daily schedule based on the time-of-use (TOU) rates of Austin Energy Peak Shift Pricing program. - ESS would be charging from 9am to 1pm when solar generation peaked - ESS would be discharging from during on-peak hours (4pm to 6pm) - Charge/discharge rates (i.e. power) were calculated such that the state-of-charge of energy storage system at the beginning of the day would be equal the state-of-charge at the end of the day. 	<ul style="list-style-type: none"> - Maximizing self-generation / limiting back-feeding based on the following algorithm: <ul style="list-style-type: none"> • charge ESS if the net metered load becomes negative • stop charging ESS if the net metered load goes positive • start discharging ESS if the net metered load goes above 70% of maximum load* • stop discharging ESS if the net metered load goes below the 30% of maximum load* <p>*thresholds are based on a data analysis conducted on Pecan Street residential load and PV generation data. Analysis showed that for most homes, daily load variations are often between 30-70% of annual peak load, and thereby load measurements within this range would be treated as normal load variations. Any time load goes above 70% of annual peak load it is flagged as a peak event and must be shaved. Similarly, any time load falls below 30% of annual peak it is flagged as a valley event and that must be filled.</p>	<ul style="list-style-type: none"> - Optimize all value streams together. - DERO would run the following applications RTPD, PLR, EA - Aggregators would receive commands from DERO and dispatch them among residential energy storage systems. 	<ul style="list-style-type: none"> - Optimize all value streams together - DERO would run the following applications RTPD, PLR, EA
<i>PV - Residential Direct Utility Control</i>	Real power generation only No Var support	Real power generation only No Var support	Provide reactive power support	Real power generation only No Var support
<i>PV - Res Read Only</i>	Real power generation only No Var support	Real power generation only No Var support	Static PF setpoints	real power generation only No Var support
<i>ESS - Aggregated Commercial</i>	<ul style="list-style-type: none"> -fixed daily schedule for energy arbitrage based on the time-of-use (TOU) rates of Austin Energy Peak Shift Pricing program. -energy storage would be charging from 9am to 1pm when solar generation peaked - energy storage would be discharging from during on-peak hours (4pm to 6pm) - charge/discharge rates (i.e. power) were calculated such that the state-of-charge of energy storage system at the beginning of the day would be equal the state-of-charge at the end of the day. 	<ul style="list-style-type: none"> -demand charge reduction which would be activated when the net metered load goes above the threshold. The threshold would vary with the load season. Based on load profile analysis three seasons were identified in Austin Energy's circuit <ul style="list-style-type: none"> - January to May (first shoulder season) - June to September (peak season) - October to December (second shoulder season) For each season, the threshold was defined as 150% of the average load in that season* <p>*threshold calculated based on a data analysis on the load and PV generation data of identified commercial customers</p>	<ul style="list-style-type: none"> - Optimize all value streams together with demand charge reduction having priority - DERO would run the following applications while giving priority to DCR: RTPD, PLR, EA, CM, DCR - When DCR was active, commands from DERO would be rejected by energy storage systems. - When DCR was not active DERO could use available capacity for other applications. 	<ul style="list-style-type: none"> - Optimize all value streams together with demand charge reduction having priority - DERO would run the following applications while giving priority to DCR: RTPD, PLR, EA - When DCR was active, commands from DERO would be rejected. - When DCR was not active DERO could use available capacity for other applications.

Pending Approval from U.S. Department of Energy

DER Type	None: Rudimentary, Manual, Scheduled	Autonomous: Local intelligence, but no coordination; "set it and forget it"	Fielded SHINES	Holistic controls: Modeled in addition to Fielded SHINES
<i>EV</i>	<ul style="list-style-type: none"> - Vehicles would be charging without any time/energy restrictions - Historical data from multifamily and Pecan St was directly used to create the time-series representing no controls charging behavior 	<ul style="list-style-type: none"> - Vehicles would be enrolled in a TOU program - Historical data from EV360 Time-of-Use Pilot Program was used to create the time-series representing autonomous charging behavior 	N/A	<ul style="list-style-type: none"> - Available and controllable vehicles would follow DERO's commands for the following applications: RTPD, PLR, EA - Vehicle-to-Grid (V2G) was assumed to be available to controllable vehicles - Average daily availability was modeled using Pecan Street historical data, and varied between 5% to 20% of total EV capacity - Unavailable and uncontrollable vehicles would be modeled using historical charging data only as they were deemed uncontrollable
<i>Load Control</i>	<ul style="list-style-type: none"> - No load control was assumed in the no controls scenario 	<ul style="list-style-type: none"> - No load control was assumed in the autonomous controls scenario 	N/A	<ul style="list-style-type: none"> - Load control algorithm shifted energy usage of three controllable, high-consumption residential devices HVAC, electric water heaters, and pool pumps to off-peak hours; algorithm was applied in the holistic controls scenario

5.2 SHINES Control Applications

The SHINES control solution comprises a fleet manager and optimizer, DERO, and local intelligence at the individual ESS and PV asset level. This section describes the applications implemented by DERO and the single-application performance testing that was carried out using detailed system models.

Three ERCOT market applications are implemented as part of the Austin SHINES project: peak load reduction, real-time price dispatch, and energy arbitrage. Two applications are implemented as part of the circuit manager functionality: voltage support and congestion management. A customer-focused application, demand charge reduction, is also implemented.

5.2.1 Peak Load Reduction

The goal of the Peak Load Reduction (PLR) application is to reduce Austin Energy's load and hence its load ratio share during ERCOT's peak load over four 15-minute peaks in the months of June through September of each year, also known as 4 Coincident Peak (4CP). ERCOT calculates the annual TCOS for each DSP in ERCOT by multiplying the wholesale transmission fee of each TSP by the average 4CP load of each DSP in ERCOT. Each MW of load that can be reduced during the 15-minute ERCOT peak intervals each month can help reduce Austin Energy's payments to ERCOT transmission service providers for the entire following year.

The PLR application is a real-time application. The primary operation of the application occurs in real time based on the actual ERCOT system load. If the current interval is a new peak load, then ESS will discharge. If the current interval is not a peak load, then the application will not cause any action. The application looks six hours into the future to anticipate possible peaks and increase ESS SOC if necessary, to be ready to discharge during a peak.

ERCOT measures Austin Energy's load at Austin Energy's metered boundary (which it has visibility to through ERCOT-Polled Settlement (EPS) meters). ERCOT also has visibility into Austin Energy's registered resources. Any resources larger than 1MW require registration with ERCOT and EPS metering. When ERCOT calculates 4CP, they base it off the load at the metered load zone boundaries, but they also add in any generation from registered resources internal to Austin Energy's boundary used to off-set that load. Thus, registered resources do not add full value to the peak load reduction (4CP) use case. However, DERO needs to make sure that the registered resources are not creating load (charging) during the 4CP intervals.

Current peak value (CPV) is the highest demand value yet established this month. If the system load goes above this value, it creates a new 4CP interval. During 4CP months the current peak value is initialized to zero at the start of the month. During the calendar month, each actual interval MW will be compared to this number, and if current interval MW is greater than current peak value, the current peak value will be updated with the higher value. Figure 5-1 shows how the CPV (in blue) increases over the course of a month as the system load (in orange) reaches new maxima.

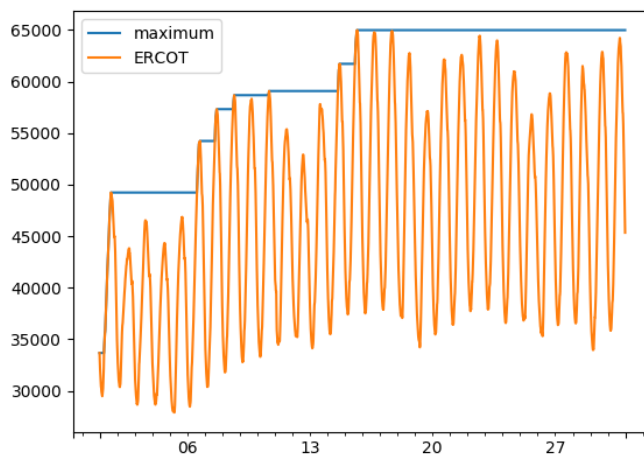

Figure 5-1 Current Peak Value in June 2019

Unless the peak load forecast is 100% accurate, focusing on a single 15-minute interval to discharge ESS can pose uncertainty for such a small window of time. Rather, the forecasted interval should be considered the center of a forecasted range of intervals that should be treated as possible peaks. The application defines a Forecasted Peak Window (FPW) which is equal to the interval(s) that are forecasted to be higher than the current peak value. The load forecast may have a number of intervals that are predicted to be higher than the current month's peak interval. The number of intervals the battery can discharge depends on State-Of-Charge (SOC), power and capacity. Another parameter the application uses is the Available Offset Duration (AOD), which is number of intervals the battery can discharge at the specified power. The ESS charges and discharges while carrying out the PLR application's main function, which has the effect of incidental arbitrage, or net wholesale energy purchases. PLR does not take the SPP price into account, so any benefit here is a happy coincidence. However, since PLR is generally charging in the morning when prices are generally lower and discharging in the afternoon when prices are generally higher, it would not be surprising to see some economic gain by coincidence.

5.2.2 Real Time Price Dispatch

The Real-Time Price Dispatch (RTPD) application takes advantage of volatility in real-time energy prices. The price volatility is typically higher in areas that do not have a capacity market (such as ERCOT). By design, ERCOT allows energy prices to spike high to encourage generation to come online. The value of real-time price dispatch is realized by purchasing energy (charging) when prices are low and selling energy (discharging) when prices are high. The time horizon at which RTPD application looks ahead is from 5 minutes to 6 hours, but it must act as a real-time application and automatically deploy schedules as frequently as 5 minutes.

Typically, price spikes only last a short (5-15 minute) period, so short-term prediction and fast response is important. It will be almost impossible to predict the price spikes more than an hour in advance, but the goal is to use a 5-minute price forecast (and possibly other inputs) to help predict rising or falling prices. As a starting point, it is not expected that the forecast will be able to predict the spikes, but rather just general trends above/below average. If a spike was not forecasted but occurred at the first interval of a SPP, then DERO still tries to capture part of the value for that SPP by reacting. If the price spike occurs only in the first of three SPP intervals, an ESS can discharge in the second and third interval and still receive 2/3 of the value of the price spike. If the price spikes in the second of three SPP intervals, an ESS can discharge in the third interval and still receive 1/3 of the value of the price spike.

All assets that have controllable real power can contribute to RTPD. Energy storage, being bi-directional, can take advantage of both spikes and troughs in prices. For PV, it would only make sense to curtail if prices are negative.

Figure 5-2 shows an example of an RTPD report in DERO. Two price spikes can be observed, at 10:30 and 10:50. A discharge event was triggered after the first spike and continued throughout the second spike. Most of the revenue was made when the second spike happened as the ESS was discharging from the beginning of the event until it ended at 11:00.



Figure 5-2 Sample real-time price dispatch report

5.2.3 Energy Arbitrage

The basic energy arbitrage concept is to buy energy when prices are low and sell it when prices are high. The mechanism is similar to RTPD, but the time scale is different as RTPD happens in real-time; energy arbitrage is more of a day-ahead application. Most markets have price variation over the course of a day where prices increase during times of high demand and decrease when demand is low (often in the middle of the night). Not all utilities will have price forecasts available, so an optional load forecast can be used as a proxy for price. The Energy Arbitrage (EA) application is a day-ahead application and creates recommendations based on forecasts and settings.

All assets that have controllable real power can contribute to this application. Energy storage, being bi-directional, can take advantage of both spikes and troughs in prices. For PV, it would only make sense to curtail if prices are predicted to be negative.

The first step in running the EA application is to select the EA mode (load-based or price-based). If the user has selected load-based EA, then the load forecast must be transformed into an approximate price forecast. This must be performed so that it can be optimized against other applications that are based on price. To do so, the application maps the minimum and maximum load over the day to the minimum and maximum average prices from the previous three days.

Once the EA application mode is determined and all the preprocessing steps are done, the application will create constraints (low load, high load, and peak hours, user overrides, etc.) for input into DERO's optimization engine.

The EA application is expected to have a significantly smaller maximum potential value than the PLR and RTPD's maximum potential value. Single-application performance testing has not been carried out.

5.2.4 Congestion Management

Congestion events in power systems occur when electricity flow across a system component (such as distribution line or transformers) exceeds safe design capacity. High penetration of DERs in distribution systems increases the probability of congestion events, at the distribution level. Because congestion can cause voltage and overloading problems, it is important for the distribution system operator to prevent and manage congestion. The goal of the

congestion management (CM) application is to use active power capability of DERs on a circuit to relieve congestion problems in the circuit. This application helps utilities prevent potential load shedding events, increase life of assets including congested lines and overloaded transformers, and increase hosting capacity of distribution circuits for renewable energy.

CM methods are more broadly implemented for transmission systems and they aim to handle network access in the presence of congestion. In transmission systems, they can be generally classified into preventive and remedial methods. Preventive CM methods allocate available capacity prior or during the planning procedure, and remedial CM methods re-dispatch resources after capacity allocation in real-time.

Similar to transmission systems, in distribution systems, the CM application provides a two-stage solution. The congestion management application checks the current power flow magnitude on the circuit to detect congestion events every 5 minutes, based on two sets of user-defined limits. The first set of limits takes preventive measures, whereas the second takes remedial ones. The first stage is applied when the application detects the first pre-defined limit. In this stage, the application sends the necessary inputs to the optimization engine, so that the base model can be updated according to the new inputs. When congestion is more severe, and the remedial limits are triggered, i.e., application detects the second pre-defined limit, the second stage of the solution will be applied which forces the base optimization model to give priority to congestion relief and ignore other economic applications. The congestion management application does not reserve any energy or power when day-ahead or interval-ahead applications run.

Every DER with controllable active power capability can contribute to congestion solution. Because of radial topology of distribution systems, congestion management will be useful for the circuits that have controllable asset(s) downstream of the measurement point.

5.2.5 Demand Charge Reduction

A proxy for the demand charge reduction (DCR) algorithm was developed in GridLAB-D based on the provided data by STEM as part of the SHINES project. Figure 5-3 shows the performance of the demand charge reduction (DCR) algorithm. When the net active power load exceeds the threshold, a DCR event starts. During the event, the algorithm sends a discharge command to the ESS inverter to reduce the net load. Discharging stops if 1) battery state-of-charge (SOC) goes below the minimum SOC defined for the ESS, or 2) if net active power load goes below the threshold. When net active power load is below the threshold, algorithm sends charging command to the ESS inverter. Charging continues until 1) battery SOC reaches the determined target SOC, or 2) when the net reactive power load exceeds the threshold.

Determining the right load threshold is very important for the effective performance of the DCR algorithm. While STEM uses a more sophisticated algorithm to determine the threshold, we took a simple approach and load data analysis for 2016 showed that Austin Energy load follows a seasonal pattern. Three loading seasons were identified:

- January to May (first shoulder season)
- June to September (peak season)
- October to December (second shoulder season)

A detailed load and PV generation data analysis was conducted on identified commercial customers to determine the appropriate load threshold. Analysis showed that for most customers, on average, the daily peak happened when the load exceeded 1.5 times the average load in the season.

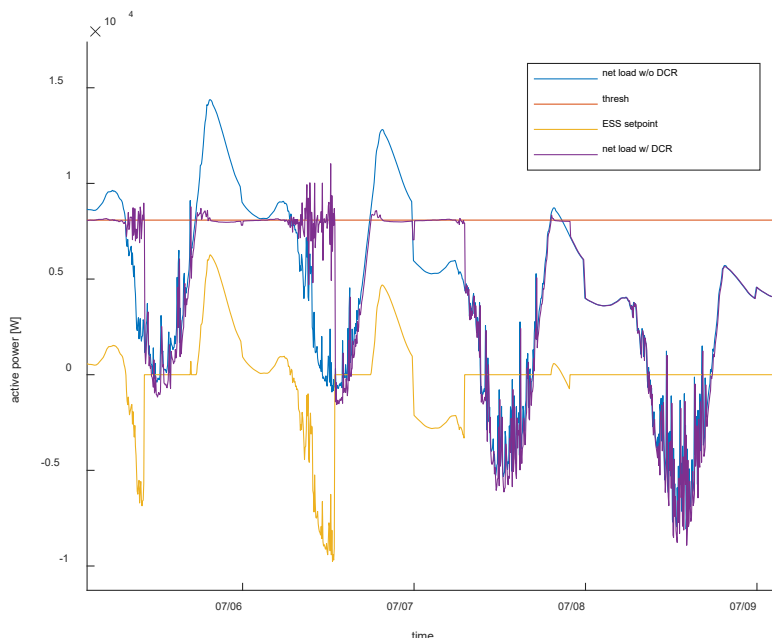

Figure 5-3 DCR algorithm (proxy for STEM aggregator DCR algorithm) performance

5.2.6 Voltage Support

A satisfactory voltage profile on a distribution circuit must maintain the following qualities:

- Voltage at any node within the distribution circuit must remain within ANSI C84.1 limits of 0.95 to 1.05 at the point of service
- Voltage at any node with the distribution circuit must remain relatively smooth and free of problematic volatility and variability

Volatility is deemed problematic when it causes flicker which imposes visual discomfort on humans, or when it results in excessive tap changing operations of voltage regulating devices such as the substation transformer’s LTC. Since flicker is a sub-second phenomenon, its mitigation is beyond the scope of this work. Hereinafter, problematic voltage volatility refers to the fluctuations that cause excessive LTC actions.

The intermittency and rapid fluctuations of solar generation, especially at higher penetration of solar, may lead to voltage volatility in the distribution system. A voltage support application was developed to mitigate this volatility and improve the quality of voltage in the system.

The Voltage Support (VS) application aims to provide voltage control for inverter-based DERs including solar PV and ESS. The goal of this application is to mitigate voltage volatility throughout the distribution system and maintain the voltage within acceptable range by adjusting reactive power output of DER inverters. Each DER operates on a local mode (e.g. fixed reactive power output, power factor, or Volt-Var mode) set by the VS application and reacts to local measurements. The VS application sets the DER mode when the application starts and changes the settings (e.g. power factor set-point for power factor mode, or Volt-Var curve for Volt-Var mode) as necessary. The VS application operates as a real-time application within DERO which generates new set-points every 5 minutes. The normalized moving standard deviation of voltage differences (NMSDD) at specific location(s) is used as the metric of voltage volatility. NMSDD is calculated every 5 minutes, as follows:

$$NMSDD = \frac{\sqrt{\frac{\sum_{t=1}^{N-1} (\delta V_t - \delta \bar{V})^2}{N-1}}}{(V_H - V_L)}$$

where is V_t voltage magnitude sample at time t , N is the number of voltage samples in a 5-minute window, and

$$\overline{\delta V} = \frac{\sum_{t=1}^{N-1} \delta V_t}{N - 1}$$

$$\delta V_t = V_t - V_{t-1}, t = 1, 2, \dots, N - 1$$

V_H and V_L are maximum and minimum allowable voltage magnitudes set by the user and are described later in this Section.

Inputs to the VS application are:

- Meter voltage readings
- Solar forecast

For the first step, the VS application receives voltage readings from the meter(s) and converts them to a per unit base. For each DER, depending on system topology, voltage fluctuation vulnerability and other technical considerations, one or more meters are selected to participate in the VS application. The set of meters used can be different for each DER.

After receiving the meter data, the application calculates the following terms:

- Historical voltage deviation, which is calculated over a configurable time window called Voltage Moving Window. Meter readings of selected meters are pulled from the Pi database (which stores data at 1- or 2-second rates) and the historical voltage deviation is calculated over the Voltage Moving Window. Meters at different locations can have different contributions to the historical voltage deviation, and this is determined by the assigned weighting factors to the meters.
- Forecasted voltage deviation, which is a term that maps the forecasted solar volatility onto voltage fluctuations. To calculate the forecasted voltage deviations, the first application calculates the standard deviation of solar output at various locations over a time-window called the Solar Moving Window (which can be of different length than that of Voltage Moving Window). Again, solar generation readings are pulled from the Pi database. For every solar location, the voltage deviation at that location is also calculated over the Solar Moving Window. Note that solar location voltage deviation is similar to historical voltage deviation, but it is calculated over the Solar Moving Window and at a location with installed solar PV. To calculate the forecasted voltage deviation, a cross correlation matrix is formed between all calculated historical solar deviation and historical voltage deviation over the Solar Moving Window. Using this cross-correlation matrix, and the available solar forecast at each location, the solar forecast will be “converted” to forecasted voltage deviations at that location.
- Total voltage deviation, which is the weighted sum of historical and forecasted voltage deviations. The weighting factors (which are scalars between 0 and 1) can be configured by the user.
- After the VS application calculates the total voltage deviation, it needs to ‘distribute’ the total deviation among controlled DER inverters to calculate the set-points of each DER. This is done using a set of weighting factors.

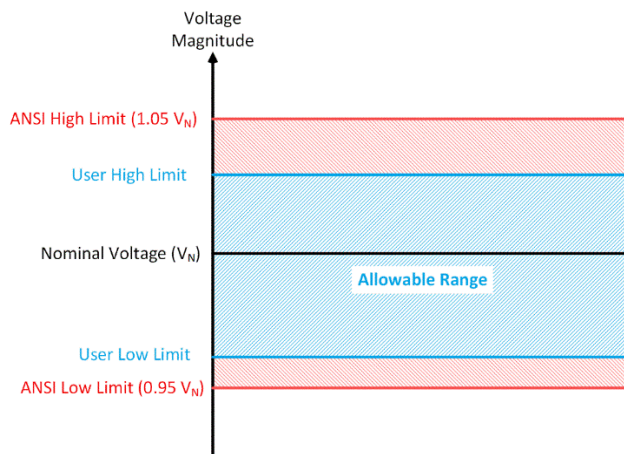

Figure 5-4 Higher limit (top red shaded area), lower limit (bottom red shaded area) and control (blue shaded are in the middle) zones

The VS application divides the allowable voltage range (the 0.95-1.05 per unit range defined by ANSI C84.1) into three separate voltage zones defined as: higher limit zone, control zone, and lower limit zone. The higher limit zone is a voltage band defined around the voltage high limit (V_H) that is set by the user (this can be smaller than the ANSI high limit). Similarly, the lower limit zone is a voltage band around the voltage low limit (V_L which can be larger than the ANSI low limit). The control zone occupies the rest of the space left in the allowable voltage range. If the DER inverter local voltage falls into the higher/lower limit zones, the DER will absorb or inject maximum reactive allowable power (maximum reactive power can be set by user and can be different from the actual capacity of the DER). On the other hand, if the voltage falls into the control zone, the set-point would be calculated as a fraction of the maximum allowable reactive power. This fraction is the ratio of assigned DER voltage deviation to the maximum allowable voltage deviation which is defined as either the difference between the high voltage limit and local voltage or the difference between the low voltage limit and local voltage, whichever is smaller.

The advantage of the VS application over more traditional voltage support methods like regular constant power factor control or Volt-Var control is that

- It includes the solar forecast in voltage control
- It allows for the use of non-local voltage signal which increases the ability for a DER to contribute to voltage support solutions for the distribution circuit at-large, not just locally
- It takes advantage of responsiveness of power factor or Volt-Var control curves at the local level, but the fleet manager can adjust the responsiveness so that the optimal level of voltage support, as balanced against real power applications, can be supplied

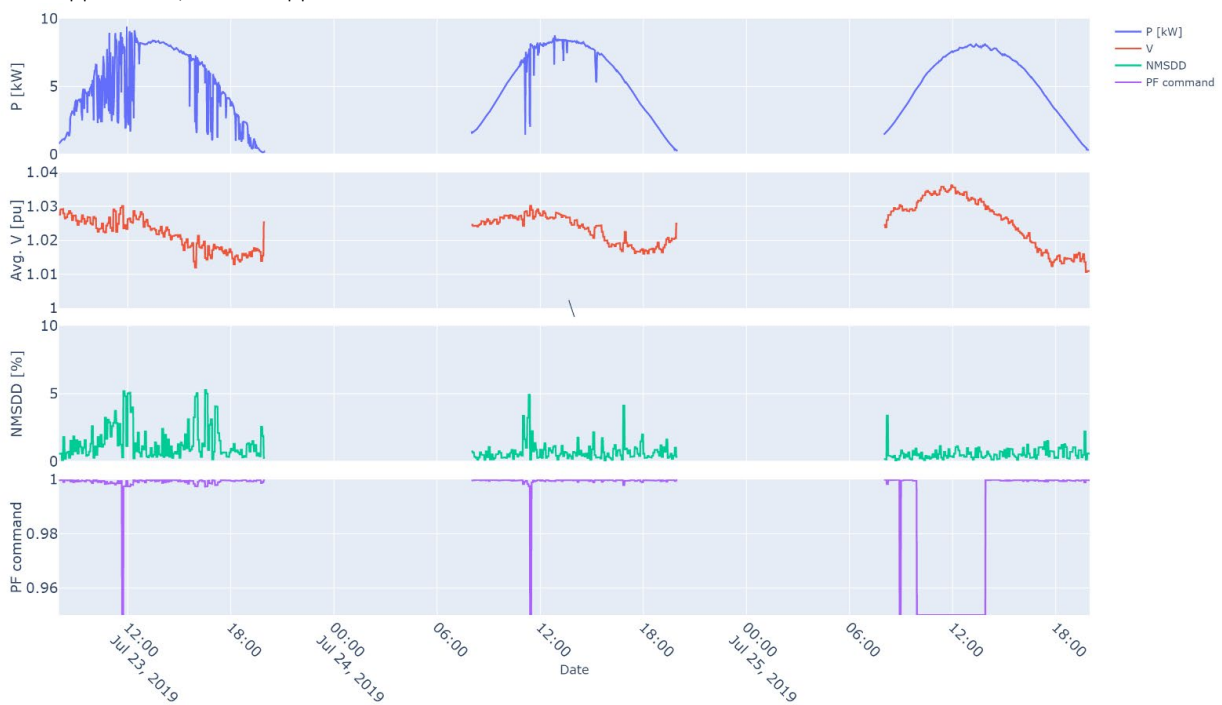

Figure 5-5 Voltage Support Application performance

Figure 5-5 shows how VS application work in the power factor mode for a solar inverter, assuming V_L and V_H to be 0.97 and 1.03 p.u. and PF control zone to be 0.95 (lagging) to 1. From left to right, the first column of plots represents a day with high solar variability, the second column represents a day with moderate variability and the third column represents a sunny day with no solar variability. First and second row plots show solar generation and the POI voltage of the solar inverter. Although solar generation is volatile in the first day and parts of the second day, voltage fluctuations are not significant. As a result, NMSDD is small, yet consistent with the amplitude voltage variations. Note that maximum possible NMSDD is 100% of $V_H - V_L$ (which is $1.03 - 0.97 = 0.06$ pu in this example). Maximum NMSDD in Figure 5-5 is 5% which indicates that voltage fluctuations are not significant. The bottom row plots show how PF

command changes throughout the day. Notice that since changes in PF command is proportional to NMSSD (which is very small in this case), PF is mostly close to 1, except for the times that voltage exceeds V_H (1.03 pu) and falls into the high voltage zone in which case DERO sets the PF to the minimum lagging PF (0.95 in this example).

Section 6 System LCOE Methodology Application

This Section demonstrates the application of the System LCOE methodology developed in this document. The methodology was applied to MU circuit with 25% solar penetration and two 0.99MW/2MWh utility-scale ESS. Table 6-1 shows details of this scenario.

Table 6-1: Scenario 3

Scenario No	PV (MW)		ESS (MWh)			EV (MWh)
	Distributed	Community	Utility	Residential	Community	
3	4.9	0	4	0	0	0

Figure 6-1 shows the results of System LCOE calculations for this scenario. The $\Delta SystemLCOE_{SHINES}$ is 19% lower than the $\Delta SystemLCOE_{BASE}$ which doesn't meet the requirement of the second SHINES metric (%delta metric).

Please Note the System LCOE (\$/kWh) is represented by 3 decimal figures (in Figure 6-1 and Figure 6-2). These are rounded for display purposes, and any discrepancies to the final %delta metric can be proven through the accompanying spreadsheet *FD5_System LCOE Calculations.exe*. The %delta metric is therefore the true value in these graphs. Thus the %delta metric cannot be determined "by hand" from the significant figures provided, and should be considered a close representation for illustrative comparison.

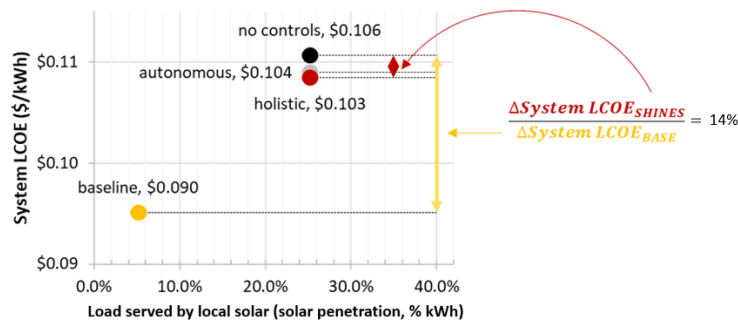

Figure 6-1 Example set of System LCOE results; MU circuit, two 0.99MW/2 MWh utility ESS, 4.9MW distributed PV

Figure 6-2 is a two-part figure that shows the same results as shown in Figure 6-1, in a different format. Figure 6-1 explicitly labels the $\Delta SystemLCOE_{SHINES}$ and $\Delta SystemLCOE_{BASE}$; in Figure 6-2 they are called out by the same red and yellow arrows but not explicitly labeled for a more compact presentation. The right panel Figure 6-2 shows the contributions to System LCOE from categories of costs.

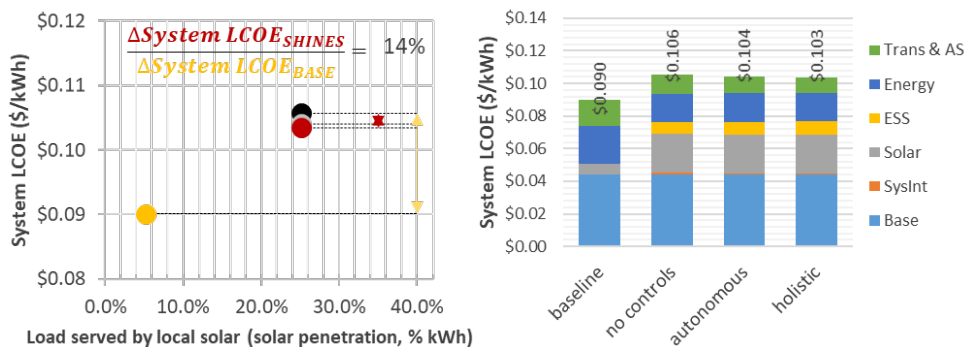

Figure 6-2 System LCOE results; MU circuit, two 0.99MW/2 MWh utility ESS, 4.9MW distributed PV

The baseline system costs in light blue are the wires, poles, transformers, substation equipment, etc., the conventional system equipment that is already present on the feeder and constant across the four scenarios. The System Integration costs in orange represent the cost of any conventional upgrades that would be required to absorb the distributed solar. A deployment of the VVO system was identified as the best approach for mitigating overvoltage. It also represents the replacement cost of secondary service transformers with a higher-rated model that experienced overloading during peak solar production. Holistic controls adjust the operation of the distributed solar and ESS so that firm capacity upgrades are not required, so this cost decreases between the no controls case and the holistic controls case. In gray is the cost of the solar PV, and the yellow is the cost of the ESS. This includes both hardware cost and the additional incremental cost of communication and controls for the cases with more sophisticated controls. The net wholesale energy costs, in dark blue, decrease significantly between the base case and the high-solar cases, since more of the energy that is needed is produced locally and less imported energy is required. There is a small decrease between the no controls case and the holistic controls case due to the opportunistic discharging of the ESS under the RTPD application. The transmission and AS cost, in green, have the most significant decrease between the no controls case and the holistic controls case, since PLR is the most valuable application. Strictly speaking, the utility-scale ESS deployment is assumed to be in the form of two assets, each limited to 0.99MW so that it can participate in PLR and reduce the transmission system costs. Breaking the utility-scale ESS up into systems that are each barely under 1MW ensures that all can participate in PLR, which is the most valuable of the wholesale market applications by a significant factor. One ESS is connected mid-feeder where the fielded MU 1.5MW ESS will be deployed, and one ESS is connected at the substation bus, like the fielded KB ESS. More detailed information about the implementation of the controls in each case can be found in Table 6-2

Table 6-2: System LCOE results for the MU circuit, two 0.99MW/2 MWh utility ESS, 4.9MW distributed PV

Scenario	Baseline	No Controls	Autonomous	Holistic
Solar PV penetration by energy (%)	5.3%	25%	25%	25%
System LCOE to Serve Load (\$/kWh)				
low DER costs, low ERCOT prices	\$0.084	\$0.096	\$0.095	\$0.094
low DER costs, high ERCOT prices	\$0.096	\$0.105	\$0.103	\$0.103
mod. DER costs, mod. ERCOT prices (charted in Figure 6-2 left)	\$0.090	\$0.106	\$0.104	\$0.103
high DER costs, low ERCOT prices	\$0.084	\$0.111	\$0.109	\$0.109
high DER costs, high ERCOT prices	\$0.096	\$0.120	\$0.118	\$0.118
System LCOE to Serve Load by Category (mod. case charted in Figure 6-2, right) (\$/kWh)				
Base distribution system infrastructure	\$0.044	\$0.044	\$0.044	\$0.044
System integration	\$-	\$0.001	\$0.000	\$0.000
Solar CapEx and OpEx	\$0.006	\$0.024	\$0.024	\$0.024
ESS CapEx and OpEx	\$-	\$0.007	\$0.008	\$0.008
EV CapEx and OpEx	\$-	\$-	\$-	\$-
Net wholesale energy	\$0.023	\$0.017	\$0.018	\$0.018
Transmission and ancillary services	\$0.016	\$0.012	\$0.010	\$0.009

The top-level results for the scenario set summarized in Figure 6-2 are detailed in Table 6-2. All costs are on an annualized basis. The net cost of energy and services imported to the system is integrated over the test year, as is the load served and solar penetration. The wholesale market costs, the sum of all energy, transmission, and ancillary service costs, are reduced by 8% by the actions of the ESS in the holistic controls case, as compared to the no controls case.

Section 7 Summary of Key Findings

This Section summarizes the main takeaways and lessons learned from applying the System LCOE methodology developed in this document.

7.1 Computational Burden

Circuit analysis was the first step of the System LCOE calculation. With MU and KB having 1768 and 4017 SPIDs, assigning yearlong 5-minute load and PV generation time-series to all (or in case of PV generation, a subset of) SPIDs made circuit analysis computationally expensive. The computational burden was especially significant for the software-in-the-loop (SiL) simulations, in which an optimization must be run (by DERO) prior to solving power flow (by GridLAB-D). The average runtime for SiL simulations was between 6 and 10 days for MU and KB respectively. This significantly long runtime made debugging and modification of simulations difficult, especially when the methodology was applied to determine the optimal mixture of assets for Austin Energy. The search for the optimal mixture required examining several simulation scenarios to determine the key parameters that had major contributions to System LCOE. As a solution, for scenarios with significant computational burden, instead of running the yearlong simulation, two 1-month simulations were run, one over a shoulder month and the other over a summer month. Yearlong simulations were run after verification of the results of 1-month simulations.

Another solution to the heavy computational burden was to reduce the entire circuit to a single node. This is equivalent to applying the System LCOE methodology only at the substation, which is the point through which all the energy, services and capacities cross into the upstream grid. This solution is feasible only when 1) the mixture of assets in the circuit, under any conditions, does not cause violations of operational limits (current and voltage), and 2) system losses are not significant enough to skew the economic calculations. Since System LCOE method is applied at a 'system' level, the System LCOE of the single-node model will be very close the System LCOE of the actual circuit if the aforementioned conditions hold true.

In case of Austin Energy, both MU and KB circuits had relatively high hosting capacity. Simulations at 25% solar penetration, did not show any significant violations of operational limits for any combination of assets, except for infrequent overvoltage confined to a small area in the circuits. The overvoltage could be easily resolved by adjusting the settings of voltage regulating devices for a high solar penetration scenario. As a result, all the simulation scenarios at 25% solar penetration could be run on a single node model instead, which could significantly reduce the computational burden as running power flow every 5-minutes would not be necessary. At 40% solar penetration however, significant solar back feeding, widespread overvoltage and voltage fluctuations, will not allow for the use of the single-node model.

Another possible solution to the heavy computational burden would be the implementation of parallel computing techniques.

7.2 Impact of Controls and Applications

Definition of DERs application and control impacts System LCOE as the value of DERs are directly tied to the applications they provide. Table 5-1 summarized the control scenarios defined in SHINES. One of the lessons learned from applying System LCOE was quantifying the value of reliability and power quality- related applications including CM and VS.

Even at 25% penetration of solar, Austin Energy circuits did not show any significant congestion or voltage issues. Originally, holistic control scenarios for ESS (utility-scale, commercial and residential) included CM and VS. However, since these applications were rarely used in the optimization, they did not offer any significant value and were excluded from the analysis to decrease the computational burden. Similarly, autonomous and holistic control of solar PV (distributed and community) included off-unity power factor to provide voltage support. Since there were no real voltage issues, off-unity power factor operation of solar inverters did not create a significant value and was excluded from the control scenarios.

The analysis of the autonomous control scenario with 25% distributed solar penetration showed that using a single static off-unity power factor setting (0.9 lagging, for this case) for all or a large population of solar inverters could result in a significant reactive power flow throughout the system and consequently through the substation

transformer. The excessive reactive power load resulted in an increase in system losses and LTC operations. Although off-unity power factor is an effective solution to overvoltage and voltage fluctuation issues at high penetration of solar, it must be implemented in locations that experience those issues and benefit from it most, or the off-unity power factor setting must be determined dynamically by using a more sophisticated logic. Otherwise, overcompensation of reactive power in the circuit can have a detrimental impact on the operation and consequently, the economics of the circuit.

The analysis of the holistic control scenario with 25% distributed solar showed that dynamic off-unity power factor settings for solar inverters did not create operational issues, because the power factor deviated from unity in proportion to measured voltage fluctuations. Since voltage fluctuations were small and infrequent, power factor was close to unity most of the time. Solar inverters needed to be equipped with communication devices to receive dynamic power factor commands from DERO. The communication devices were costly (especially in the case of using cellular communication), and because the dynamic off-unity power factor operation did not present a significant value, the cost of communication equipment outweighed the benefit of dynamic off-unity PF. As a result, even in the holistic control scenario, unity power factor operation of solar inverters was sufficient.

Another lesson learned from applying System LCOE was that in Austin SHINES PLR was by far the most valuable application, compared to EA and RTPD. Holistic control was the only successful control strategy in capturing the full value of PLR. Therefore, the most significant difference between no controls, autonomous, and holistic strategies was in the value of PLR. The analysis of System LCOE results for 1-month simulations showed that in shoulder months when there was no 4CP value to capture, no controls, autonomous and holistic controls had very similar System LCOE and the Δ metric was very small. Again, this signifies the importance of selection of controls and applications based the system characteristics and energy market regulations and policies.

Appendix

A. Fielded DER Costs

		unit cost	yoy price decline	2020 unit cost	unit	lifetime (years)	yearly unit cost	unit
capital cost of distributed solar	lo	\$2,813	6%	\$2,336	/kW	25	\$93.45	/kW/year
	md	\$3,516	6%	\$2,920	/kW	25	\$116.81	/kW/year
	hi	\$4,219	6%	\$3,504	/kW	25	\$140.18	/kW/year
operating cost of distributed solar	lo	-	-	-	-	-	\$19.20	/kW/year
	md	-	-	-	-	-	\$24.00	/kW/year
	hi	-	-	-	-	-	\$28.80	/kW/year
controls cost of distributed solar (autonomous)	lo			\$0	/kW	25	\$0.00000	/kW/year
	md			\$0	/kW	25	\$0.00000	/kW/year
	hi			\$0	/kW	25	\$0.00000	/kW/year
controls and comms cost of distributed solar (holistic)	lo						\$0	/kW/year
	md						\$0	/kW/year
	hi						\$0	/kW/year
capital cost of community solar	lo	\$2,045	6%	\$1,698	/kW	25	\$67.94	/kW/year
	md	\$2,556	6%	\$2,123	/kW	25	\$84.92	/kW/year
	hi	\$3,067	6%	\$2,548	/kW	25	\$101.90	/kW/year
operating cost of community solar	lo	-	-	-	-	-	\$19.20	/kW/year
	md	-	-	-	-	-	\$24.00	/kW/year
	hi	-	-	-	-	-	\$28.80	/kW/year
controls cost of community solar (autonomous)	lo						\$0.00	/kW/year
	md						\$0.00	/kW/year
	hi						\$0.00	/kW/year
controls and comms cost of community solar (holistic)	lo						\$0.00	/kW/year
	md						\$0.00	/kW/year
	hi						\$0.00	/kW/year
capital cost of MW-scale ESS	lo	-	-	\$450	/kWh	10	\$45.00	/kWh/year
	md	-	-	\$500	/kWh	10	\$50.00	/kWh/year
	hi	-	-	\$900	/kWh	10	\$90.00	/kWh/year
operating cost of MW-scale ESS	lo	-	-	-	-	-	\$15.00	/kWh/year
	md	-	-	-	-	-	\$20.00	/kWh/year
	hi	-	-	-	-	-	\$35.00	/kWh/year
controls cost of MW-scale ESS (autonomous)	lo						\$2.00	/kW/year
	md						\$4.00	/kW/year
	hi						\$6.00	/kW/year
controls and comms cost of MW-scale ESS (holistic)	lo	\$33	5%	\$29	/kW	10	\$2.86	/kW/year
	md	\$67	5%	\$57	/kW	10	\$5.72	/kW/year
	hi	\$100	5%	\$86	/kW	10	\$8.57	/kW/year
capital cost of commercial ESS	lo	\$800	8%	\$623	/kWh	10	\$62.30	/kWh/year
	md	\$950	8%	\$740	/kWh	10	\$73.98	/kWh/year
	hi	\$1,325	8%	\$1,032	/kWh	10	\$103.18	/kWh/year
operating cost of commercial ESS	lo	-	-	-	-	-	\$0.00	/kWh/year
	md	-	-	-	-	-	\$0.00	/kWh/year
	hi	-	-	-	-	-	\$0.00	/kWh/year
controls cost of commercial ESS (autonomous)	lo						\$1.50	/kW/year
	md						\$3.75	/kW/year
	hi						\$6.00	/kW/year
controls and comms cost of commercial ESS (holistic)	lo						\$1.50	/kW/year
	md						\$3.75	/kW/year
	hi						\$6.00	/kW/year
capital cost of residential ESS	lo				/kWh	10	\$93.44	/kWh/year
	md				/kWh	10	\$110.96	/kWh/year
	hi				/kWh	10	\$154.76	/kWh/year
operating cost of residential ESS	lo	-	-	-	-	-	\$0.00	/kWh/year
	md	-	-	-	-	-	\$0.00	/kWh/year
	hi	-	-	-	-	-	\$0.00	/kWh/year
controls cost of residential ESS (autonomous)	lo			\$0	/kW	10	\$0.00	/kW/year
	md			\$14	/kW	10	\$1.43	/kW/year
	hi			\$29	/kW	10	\$2.86	/kW/year
controls and comms cost of residential ESS (holistic)	lo						\$1.00	/kW/year
	md						\$2.00	/kW/year
	hi						\$3.00	/kW/year
yearly cost of fleet management control	lo					0	\$10,000	/year
	md					0	\$15,000	/year
	hi					0	\$30,000	/year
capital cost of EV	lo				/kWh	10	\$0.00	/kWh/year
	md				/kWh	10	\$0.00	/kWh/year
	hi				/kWh	10	\$0.00	/kWh/year
operating cost of EV	lo	-	-	-	/kWh	-	\$0.00	/kWh/year
	md	-	-	-	/kWh	-	\$0.00	/kWh/year
	hi	-	-	-	/kWh	-	\$0.00	/kWh/year
controls cost of EV (autonomous)	lo			\$0	/kW	10	\$0.00	/kW/year
	md			\$0	/kW	10	\$0.00	/kW/year
	hi			\$0	/kW	10	\$0.00	/kW/year
controls cost of EV (holistic)	lo			\$0	/kW	10	\$0.00	/kW/year
	md			\$0	/kW	10	\$0.00	/kW/year
	hi			\$0	/kW	10	\$0.00	/kW/year
controls and comms cost of load control	lo			\$0	/home	10	\$0.00	/year
	md			\$0	/home	10	\$0.00	/year
	hi			\$0	/home	10	\$0.00	/year

B. DER Costs

	Asset Name	Number	Unit Power	Unit Energy	Total Power	Total Energy	Unit Capital Cost	Total Capital Cost	Unit O&M Cost /year	Total O&M Cost /year in 2017	Lifetime	Calendar Year Capital Cost in 2017	YoY change in cost (%)	Calendar Year Capital Cost in 2020	Total O&M Cost /year in 2020
			(MVA)	(MWh)	(MVA)	(MWh)	(\$)	(\$)	(\$)	(\$)		(\$)	(\$)		
existing PV	Kingsbery residential PV	varies	varies	-	0.172	-	-	\$ 605,057	-	\$ 3,442	25	\$ 24,202.28	-	\$ 24,202	\$ 3,442
	Kingsbery commercial PV	varies	varies	-	0.304	-	-	\$ 777,883	-	\$ 6,087	25	\$ 31,115.31	-	\$ 31,115	\$ 6,087
	Mueller residential PV	varies	varies	-	1.339	-	-	\$ 4,708,892	-	\$ 26,786	25	\$ 188,355.89	-	\$ 188,356	\$ 26,786
	Mueller commercial PV	varies	varies	-	0.177	-	-	\$ 451,773	-	\$ 3,535	25	\$ 18,070.92	-	\$ 18,071	\$ 3,535
fielded SHINES assets	Kingsbery ESS	1	1.5	3	1.5	3	\$ 3,053,800	\$ 3,053,800	\$ 84,278	\$ 84,278	10	\$ 305,380	9%	\$ 230,126	\$ 63,509
	Kingsbery community PV	1	2.5	-	2.5	-	-	-	-	-	25	\$ -	-	-	-
	Mueller ESS	1	1.7	3.2	1.7	3.2	\$ 3,607,011	\$ 3,607,011.40	\$ 21,978	\$ 21,978	10	\$ 360,701.14	9%	\$ 271,914	\$ 16,562
	R DUC / Autonomous	18	0.0038	-	0.068	-	-	\$ 48,749	-	-	10	\$ 4,874.90	8%	\$ 3,796	\$ -
	R Agg	6	0.004187	0.01	0.025	0.06	-	\$ 52,027	-	-	10	\$ 5,202.68	8%	\$ 4,051	\$ -
C&I Agg	5	0.036	0.072	0.18	0.36	\$ 105,475	\$ 527,375	-	-	10	\$ 52,738	8%	\$ 41,066	\$ -	
add'l assets (modeled, not fielded)	Kingsbery PV				8.29			\$ 29,147,640		\$ 165,800	25	\$ 1,165,906	8%	\$ 907,877	\$ 129,106
	Mueller PV				4.89			\$ 17,193,240		\$ 97,800	25	\$ 687,730	8%	\$ 535,527	\$ 76,156
	Kingsbery ESS														
	Mueller ESS														
	SHINES controls: SW licence (single application)	1						\$ 250,000	\$ 250,000	\$ 37,500	\$ 37,500	10	\$ 25,000.00		\$ 25,000.00
SHINES controls: SW installation (single application)	1						\$ 250,000	\$ 250,000	\$ -	\$ -	10	\$ 25,000.00		\$ 25,000.00	\$ -

R and C&I PV costs from NREL's SAM	
DC-AC scale factor	1.2
Capital, residential PV (\$/W _{DC})	\$ 2.93
Capital, commercial PV (\$/W _{DC})	\$ 2.13
O&M, residential and commercial (\$/W _{DC} /year)	\$ 0.02
Kingsbery Energy Storage System	
Capital (including install and 3yr warranty)	\$ 3,053,800
Extended warranty	
batteries: \$20k/year*7years	\$ 140,000
PCS: to 10th year	\$ 164,348
Service/Maintenance	
ESS troubleshooting by DG-IC: \$29k/year*5years	\$ 145,000
DG-IC SW \$30k/year*9years	\$ 270,000
PCS spare parts	\$ 41,430
Container PM	
AE PM 45hrs/year*\$100/hr*10years	\$ 45,000
Fire suppression maintenance	\$ 10,000
Container spare parts \$3k/year	\$ 27,000
Mueller Energy Storage System	
Capital (including install and 3yr warranty)	\$ 3,607,011
Extended warranty	
from Younicos, inclusive \$18540/year*7years	\$ 129,780
Service/Maintenance	
from DG \$30k/year*3years	\$ 90,000
Commercial energy storage systems	
Single 36kW / 72kWh unit	\$ 105,475
Residential energy storage, aggregated	
Residential Agg #1	\$ 8,975
Residential Agg #2	\$ 8,497
Residential Agg #3	\$ 8,447
Residential Agg #4	\$ 8,454
Residential Agg #5	\$ 8,817
Residential Agg #6	\$ 8,837
TOTAL:	\$ 52,027
Residential energy storage, DUC	
Residential D-A #1	\$ 1,939
Residential D-A #2	\$ 1,981
Residential D-A #3	\$ 3,005
Residential D-A #4	\$ 2,260
Residential D-A #5	\$ 1,928
Residential D-A #6	\$ 2,235
Residential D-A #7	\$ 1,933
Residential D-A #8	\$ 1,933
Residential D-A #9	\$ 2,410
Residential D-A #10	\$ 2,242
Residential D-A #11	\$ 1,924
Residential D-A #12	\$ 2,305
Residential D-A #13	\$ 1,941
Residential D-A #14	\$ 1,954
Residential D-A #15	\$ 1,960
Residential D-A #16	\$ 2,264
Residential D-A #17	\$ 2,285
Residential D-A #18	\$ 1,954
ConnectDER	\$ 10,296
TOTAL:	\$ 48,749