

SEE SHEET 8 OF 9 FOR GENERAL NOTES AND SHEET 9 OF 9 FOR DEVICE SPACING.

|   |  |  |
|---|--|--|
| <p><b>CITY OF AUSTIN</b><br/>DEPARTMENT OF PUBLIC WORKS</p> | <p><b>ARTERIAL ONE LANE CLOSURE</b></p>  |  |
| <p><i>Keri Hundstad - Spring 1/4/11</i><br/>ADOPTED</p>     | <p>THE ARCHITECT/ENGINEER ASSUMES RESPONSIBILITY FOR APPROPRIATE USE OF THIS STANDARD.</p> | <p>STANDARD NO.<br/><b>804S-1</b><br/>1 OF 9</p> |

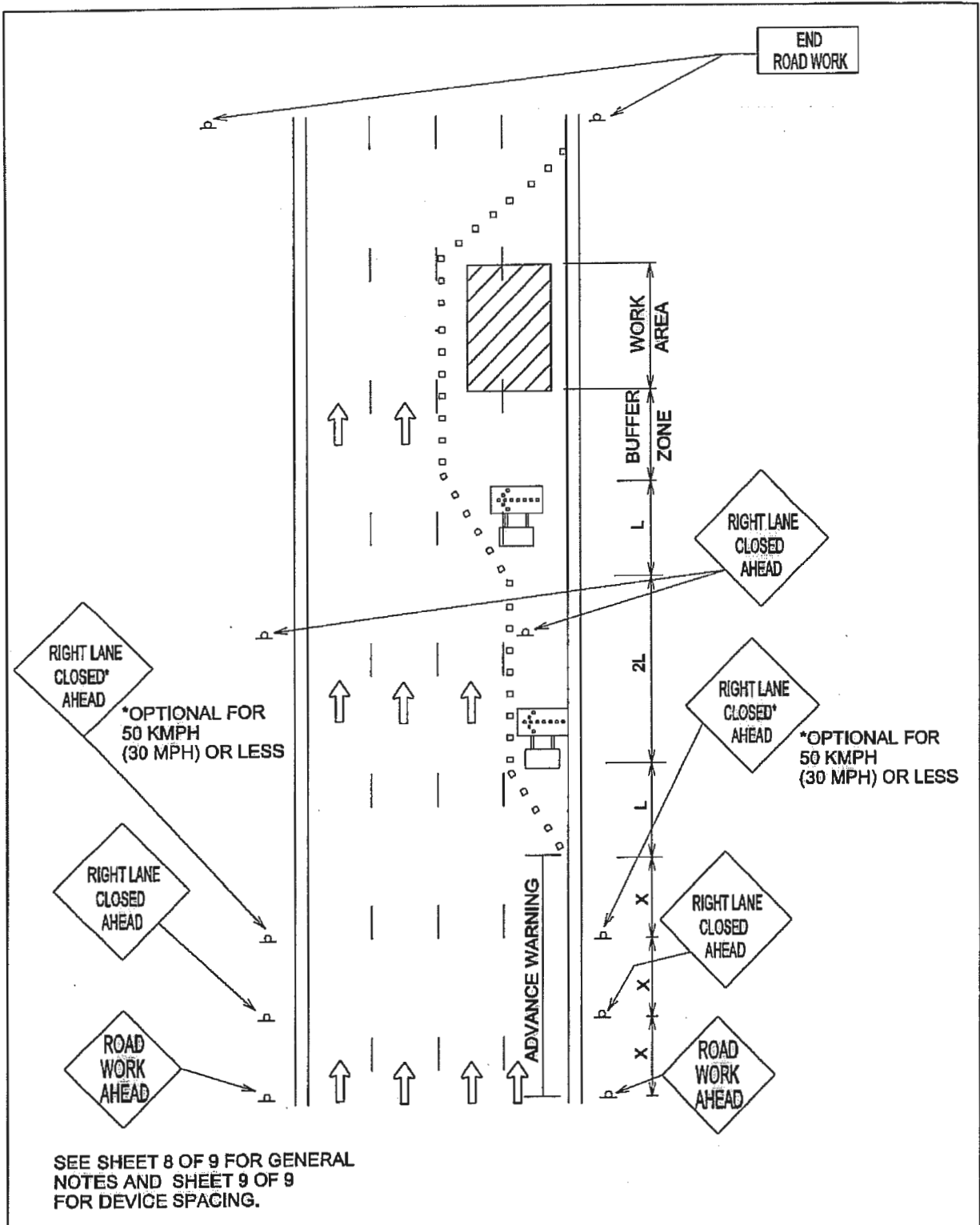

|   |  |  |
|---|--|--|
| <p><b>CITY OF AUSTIN</b><br/>DEPARTMENT OF PUBLIC WORKS</p> | <p><b>ONE WAY ARTERIAL<br/>TWO-LANE CLOSURE</b></p>  |  |
| <p><i>Ron [Signature]</i> 1/4/11<br/>ADOPTED</p>            | <p>THE ARCHITECT/ENGINEER ASSUMES<br/>RESPONSIBILITY FOR APPROPRIATE USE<br/>OF THIS STANDARD.</p> | <p>STANDARD NO.<br/><b>804S-1</b><br/>2 OF 9</p> |

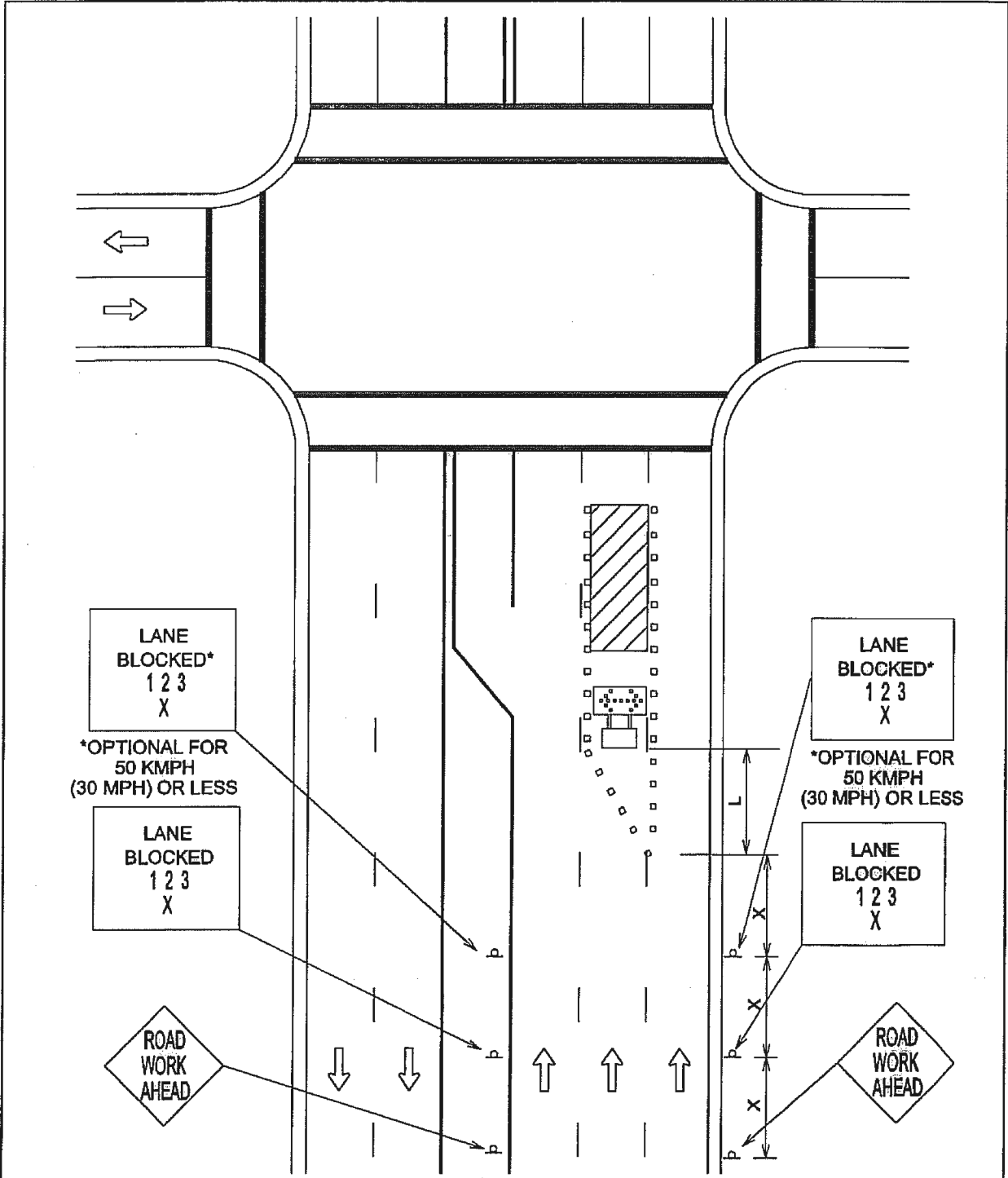

SEE SHEET 8 OF 9 FOR GENERAL NOTES AND SHEET 9 OF 9 FOR DEVICE SPACING.

**CITY OF AUSTIN**  
DEPARTMENT OF PUBLIC WORKS

**TWO WAY, DIVIDED ARTERIAL**  
**ONE LANE CLOSURE**

*Kui Nurchard-Gray* 1/4/11  
ADOPTED

THE ARCHITECT/ENGINEER ASSUMES RESPONSIBILITY FOR APPROPRIATE USE OF THIS STANDARD.

STANDARD NO.

**804S-1**

3 OF 8

SEE SHEET 8 OF 9 FOR GENERAL NOTES AND SHEET 9 OF 9 FOR DEVICE SPACING.

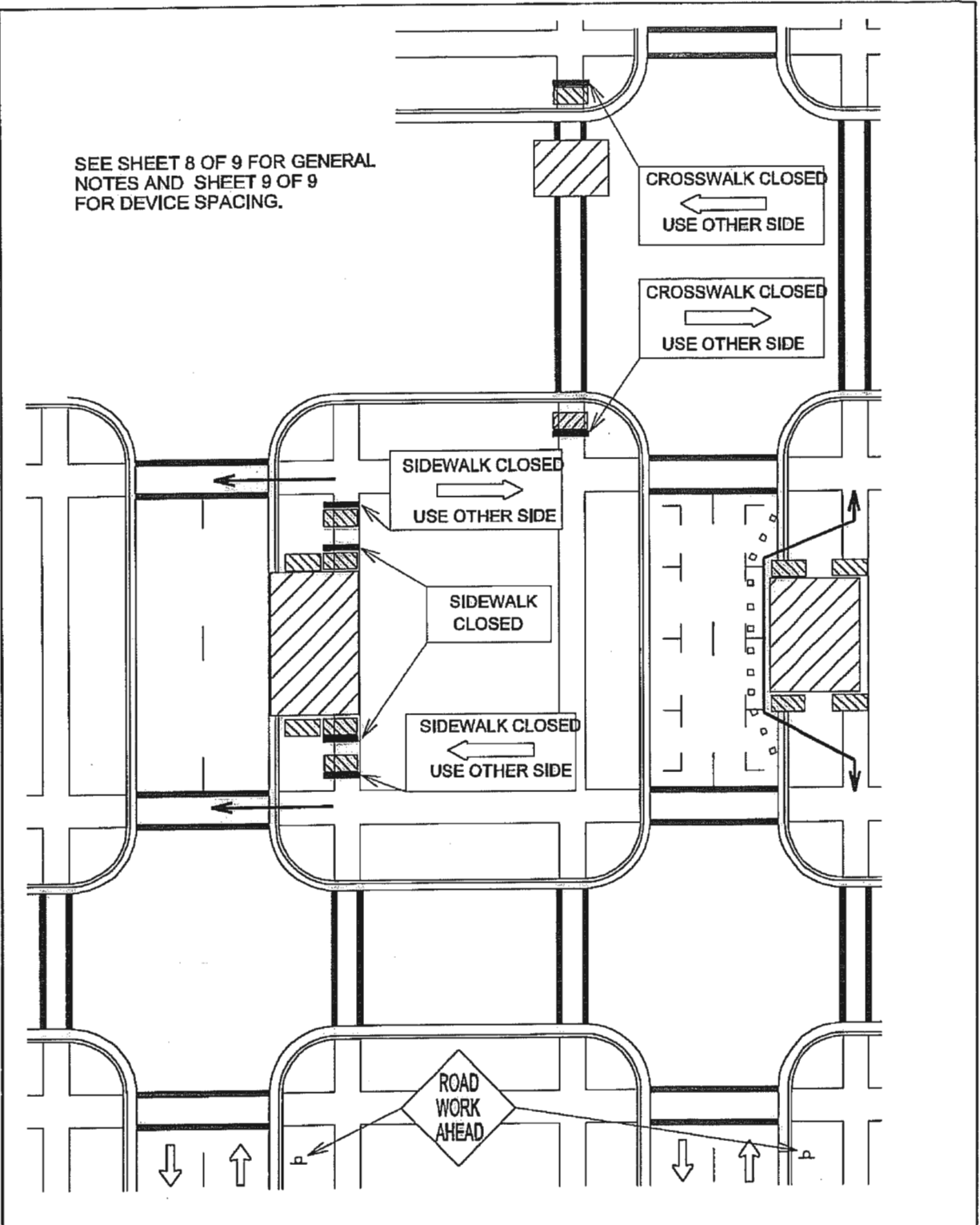

|   |  |                                       |
|---|--|---------------------------------------|
| <p><b>CITY OF AUSTIN</b><br/>DEPARTMENT OF PUBLIC WORKS</p> | <p><b>BYPASS WALKWAY, SIDEWALK AND CROSSWALK CLOSURES</b></p>                              | <p>STANDARD NO.<br/><b>804S-1</b></p> |
| <p><i>Ken Thurmond - Mayor</i> 4/4/11<br/>ADOPTED</p>       | <p>THE ARCHITECT/ENGINEER ASSUMES RESPONSIBILITY FOR APPROPRIATE USE OF THIS STANDARD.</p> | <p>4 OF 9</p>                         |

ADVANCED WARNING SIGNS  
AND SPACING SIMILAR FOR  
OPPOSING TRAFFIC.

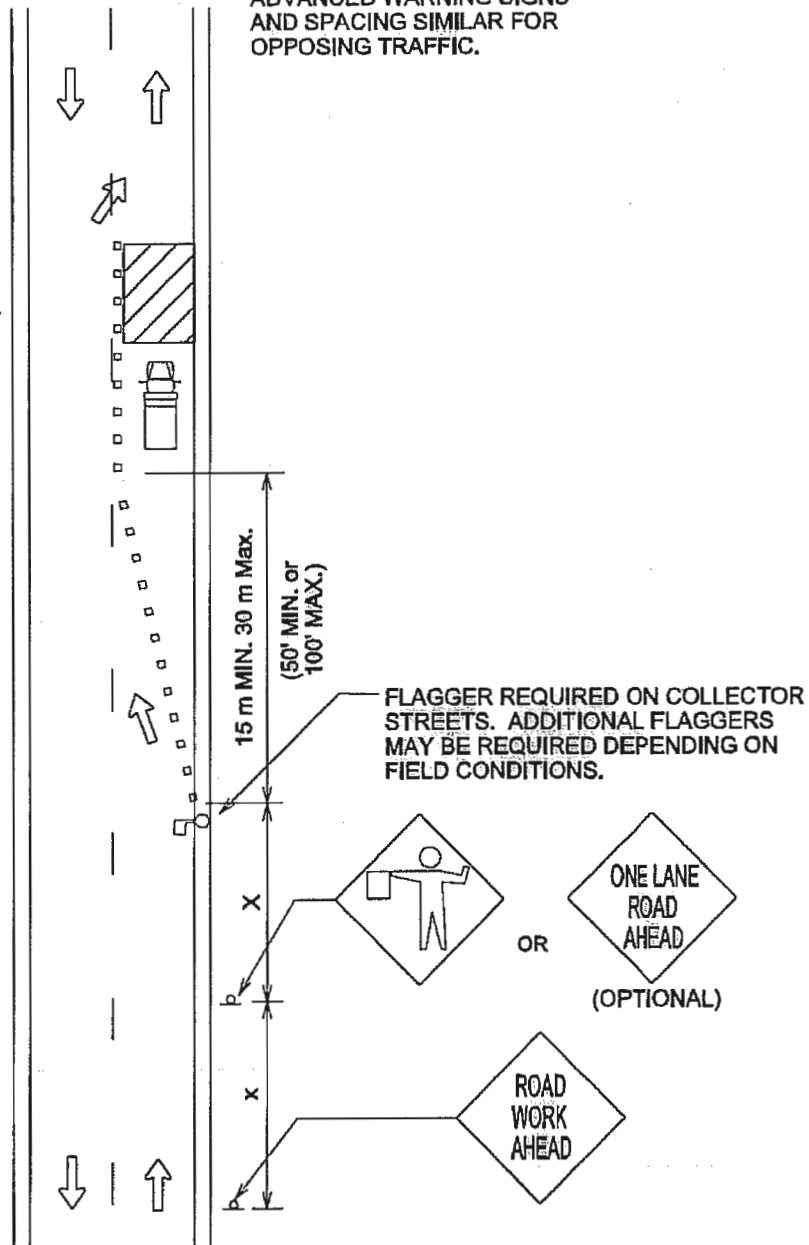

SEE SHEET 8 OF 9 FOR GENERAL  
NOTES AND SHEET 9 OF 9  
FOR DEVICE SPACING.

|   |  |                                       |
|---|--|---------------------------------------|
| <p><b>CITY OF AUSTIN</b><br/>DEPARTMENT OF PUBLIC WORKS</p> | <p><b>COLLECTOR/RESIDENTIAL<br/>LANE CLOSURES</b></p>  | <p>STANDARD NO.<br/><b>804S-1</b></p> |
| <p><i>Keri Burdick</i> 4/4/11<br/>ADOPTED</p>               | <p>THE ARCHITECT/ENGINEER ASSUMES<br/>RESPONSIBILITY FOR APPROPRIATE USE<br/>OF THIS STANDARD.</p> | <p>5 OF 8</p>                         |

ADVANCED WARNING SIGNS  
AND SPACING SIMILAR FOR  
OPPOSING TRAFFIC.

SEE NOTES 3 AND 4  
ON SHEET 8 OF 9

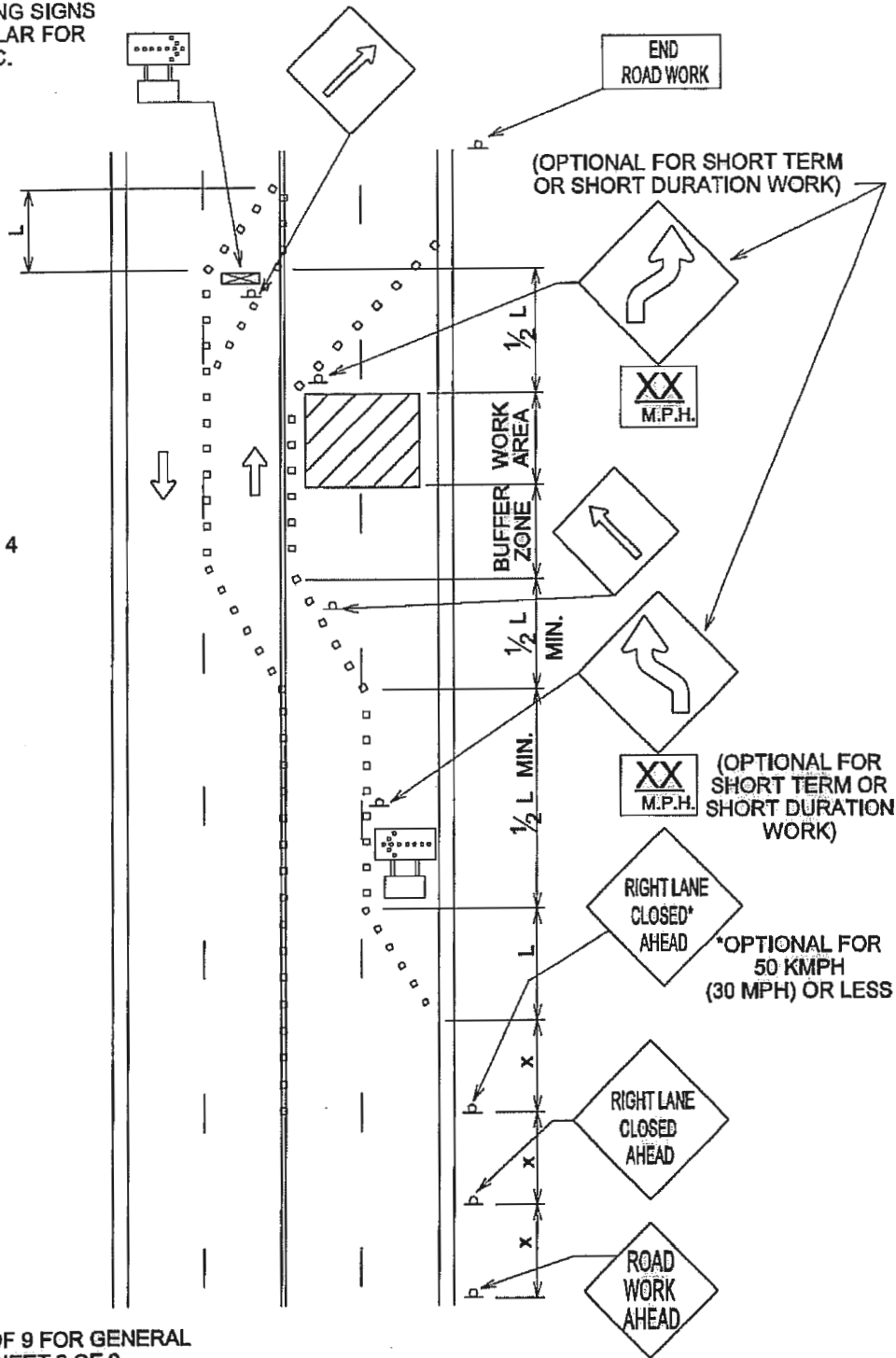

SEE SHEET 8 OF 9 FOR GENERAL  
NOTES AND SHEET 9 OF 9  
FOR DEVICE SPACING.

**CITY OF AUSTIN**  
DEPARTMENT OF PUBLIC WORKS

**TYPICAL TRAFFIC CONTROL PLAN  
FOR SHIFTING TRAFFIC**

*Phil Burdick - January 14/11*  
ADOPTED

THE ARCHITECT/ENGINEER ASSUMES  
RESPONSIBILITY FOR APPROPRIATE USE  
OF THIS STANDARD.

STANDARD NO.  
**804S-1**  
6 OF 9

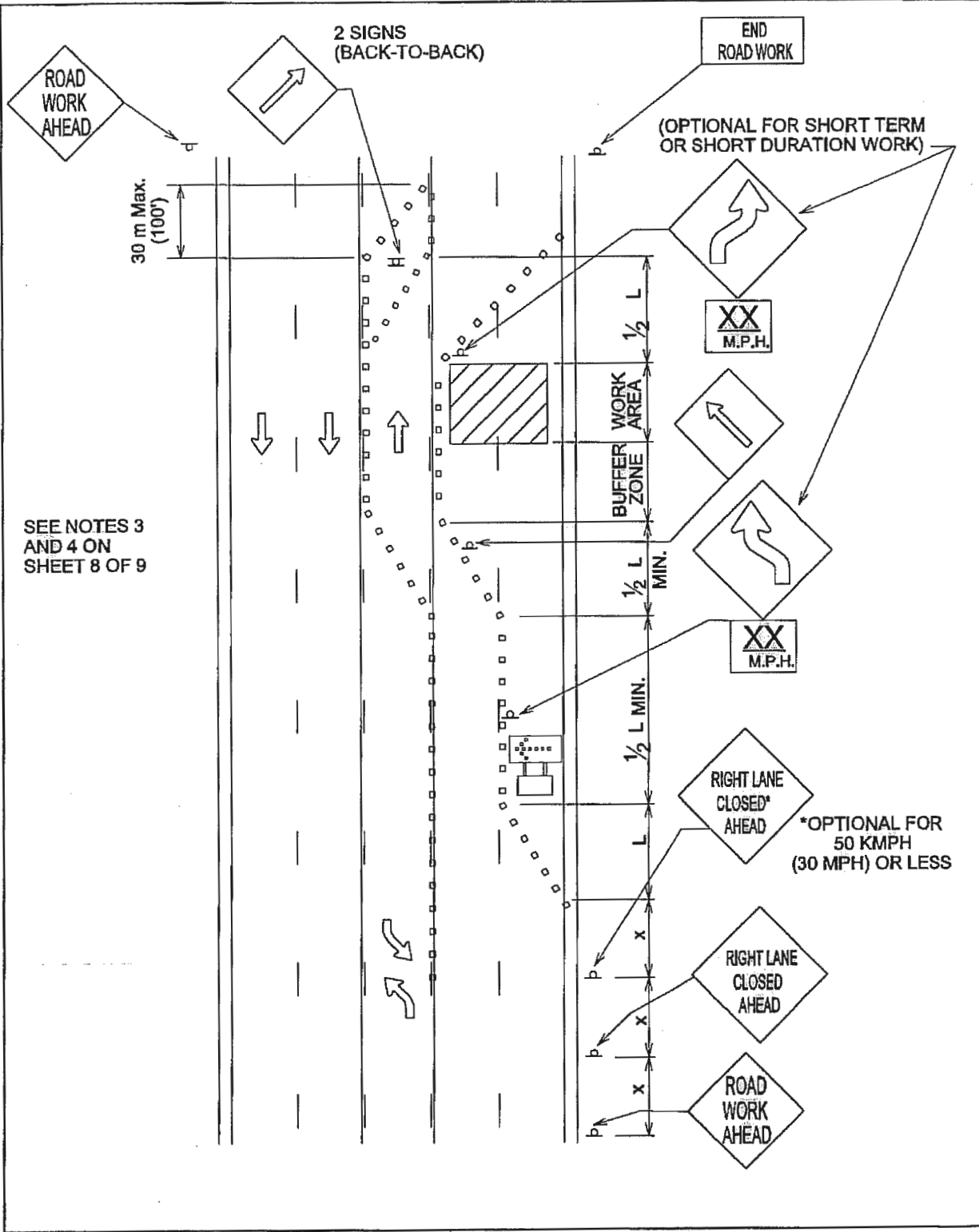

**CITY OF AUSTIN**  
 DEPARTMENT OF PUBLIC WORKS

*Tim Burdard* *Jan 14/17*  
 ADOPTED

**TYPICAL TRAFFIC CONTROL PLAN  
 FOR SHIFTING TRAFFIC**

THE ARCHITECT/ENGINEER ASSUMES  
 RESPONSIBILITY FOR APPROPRIATE USE  
 OF THIS STANDARD.

STANDARD NO.  
**804S-1**  
 7 OF 8

1. ALL SETUPS SHALL BE IN ACCORDANCE WITH THE CURRENT ADDITION OF THE TEXAS MANUAL ON UNIFORM TRAFFIC CONTROL DEVICES AND THE CITY OF AUSTIN TRANSPORTATION CRITERIA MANUAL.
2. TO DETERMINE APPROPRIATE DEVICES AND SIGN SIZES TO BE USED, REFER TO STANDARD 804S-5. SHEETS 5, 6 AND 7 OF 11.
3. FOR INTERMEDIATE-TERM SITUATIONS, WHEN IT IS NOT FEASIBLE TO REMOVE AND RESTORE PAVEMENT MARKINGS, THE CHANNELIZATION MUST BE MADE DOMINANT BY USING A VERY CLOSE DEVICE SPACING. THIS IS ESPECIALLY IMPORTANT IN LOCATIONS OF CONFLICTING INFORMATION, SUCH AS WHERE TRAFFIC IS DIRECTED OVER A DOUBLE YELLOW CENTERLINE. IN SUCH LOCATIONS, A MAXIMUM CHANNELIZING DEVICE SPACING OF 3 m (10') IS REQUIRED.
4. FOR LONG TERM STATIONARY WORK, ALL CONFLICTING PAVEMENT MARKINGS MUST BE REMOVED AND CENTERLINE STRIPING PROVIDED WHERE TWO WAY TRAFFIC IS IN ADJACENT LANES.
5. FOR TEMPORARY PAVEMENT MARKING REQUIREMENTS SEE STANDARD 804S-3.
6. FOR ONE-WAY AND MULTI-LANE ROADWAYS THE "LANE BLOCKED" SIGN MAY BE USED IN LIEU OF THE "LANE CLOSED AHEAD" SIGN. THE NUMBER OF DIGITS ON THE SIGN SHALL NOT BE GREATER THAN THE NUMBER OF LANES PRESENT ON THE ROADWAY. THE "X" SHALL BE PLACED UNDER THE NUMBER OF LANE(S) BLOCKED.
7. FOR FLAGGING OPERATION REQUIREMENTS SEE STANDARD 804S-2.
8. CONTRACTOR SHALL PROVIDE SIDEWALK CLOSURES, CROSSWALK CLOSURES OR WALKWAY BYPASS WHEREVER PEDESTRIAN MOVEMENTS ARE AFFECTED BY CONSTRUCTION ACTIVITIES. ALL SIDEWALKS AND CROSSWALKS SHALL BE ACCESSIBLE WHEN CONTRACTOR IS NOT WORKING UNLESS APPROVED BY THE TRANSPORTATION DIVISION.
9. FOR EXCAVATION PROTECTION AND SAFETY FENCE REQUIREMENTS SEE STANDARD 804S-4.
10. THE USE OF ARROW DISPLAYS ARE REQUIRED ON ALL LANE CLOSURES. THE CONTRACTOR SHALL PROVIDE ONE (1) STAND-BY UNIT IN GOOD WORKING CONDITION AT THE JOB SITE, READY FOR USE IF THE OPERATION REQUIRES 24-HOUR A DAY LANE CLOSURE SET-UPS.

|   |  |  |
|---|--|--|
| <p><b>CITY OF AUSTIN</b><br/>DEPARTMENT OF PUBLIC WORKS</p> | <p>GENERAL NOTES</p>   |  |
| <p><i>Kiri Burchard-Gunn</i> 1/4/17<br/>ADOPTED</p>         | <p>THE ARCHITECT/ENGINEER ASSUMES RESPONSIBILITY FOR APPROPRIATE USE OF THIS STANDARD.</p> | <p>STANDARD NO.<br/><b>804S-1</b><br/>8 OF 8</p> |

### Typical Transition Lengths and Suggested Maximum Spacing of Devices

| Speed<br>KMPH | Posted<br>Speed<br>MPH | Formula               | Minimum Desirable<br>Taper Lengths (L)<br>Meters (Feet) |                                       |                                       | Suggested Max.<br>Device Spacing  |                                     | Suggested<br>Sign Spacing<br>Meters (Feet) |
|---------------|------------------------|-----------------------|---|---------------------------------------|---------------------------------------|-----------------------------------|-------------------------------------|--|
|               |                        |                       | 3.0(10)<br>Offset<br>Meters<br>(feet)                   | 3.3(11)<br>Offset<br>Meters<br>(feet) | 3.6(12)<br>Offset<br>Meters<br>(feet) | On a<br>taper<br>Meters<br>(feet) | On a<br>tangent<br>Meters<br>(feet) | "X"<br>Dimension                           |
| 50            | 30                     | $L = \frac{WS^2}{60}$ | 45<br>(150)   | 50<br>(165)                           | 55<br>(180)                           | 9<br>(30)                         | 15-20<br>(60-75)                    | 40 (120)                                   |
| 55            | 35                     |                       | 65<br>(205)   | 70<br>(225)                           | 75<br>(245)                           | 10<br>(35)                        | 25-25<br>(70-90)                    | 50 (160)                                   |
| 65            | 40                     |                       | 80<br>(265)   | 90<br>(295)                           | 100<br>(320)                          | 12<br>(40)                        | 25-30<br>(80-100)                   | 75 (240)                                   |
| 70            | 45                     | L=WS                  | 135<br>(450)  | 150<br>(495)                          | 165<br>(540)                          | 13<br>(45)                        | 25-30<br>(90-110)                   | 100 (320)                                  |
| 80            | 50                     |                       | 150<br>(500)  | 165<br>(550)                          | 180<br>(600)                          | 15<br>(50)                        | 30-35<br>(100-125)                  | 120 (400)                                  |
| 90            | 55                     |                       | 165<br>(550)  | 185<br>(605)                          | 200<br>(660)                          | 16<br>(55)                        | 35-40<br>(110-140)                  | 150 (500)                                  |
| 95            | 60                     |                       | 180<br>(600)  | 200<br>(660)                          | 220<br>(720)                          | 18<br>(60)                        | 40-45<br>(120-150)                  | 180 (600)                                  |
| 105           | 65                     |                       | 195<br>(650)  | 215<br>(715)                          | 235<br>(780)                          | 19<br>(65)                        | 40-50<br>(130-165)                  | 210 (700)                                  |
| 115           | 70                     |                       | 215<br>(700)  | 235<br>(770)                          | 255<br>(840)                          | 21<br>(70)                        | 45-55<br>(140-175)                  | 240 (800)                                  |

**LEGEND**

□ □ Channelizing devices

 Trailer mounted flashing arrow board

 Flagger

|   |   |   |
|---|---|---|
| <b>CITY OF AUSTIN</b><br>DEPARTMENT OF PUBLIC WORKS | <b>DEVICE SPACING</b>   |   |
| <i>Ken Burckhard</i><br>ADOPTED 1/4/11              | THE ARCHITECT/ENGINEER ASSUMES<br>RESPONSIBILITY FOR APPROPRIATE USE<br>OF THIS STANDARD. | STANDARD NO.<br><b>804S-1</b><br>9 OF 9 |

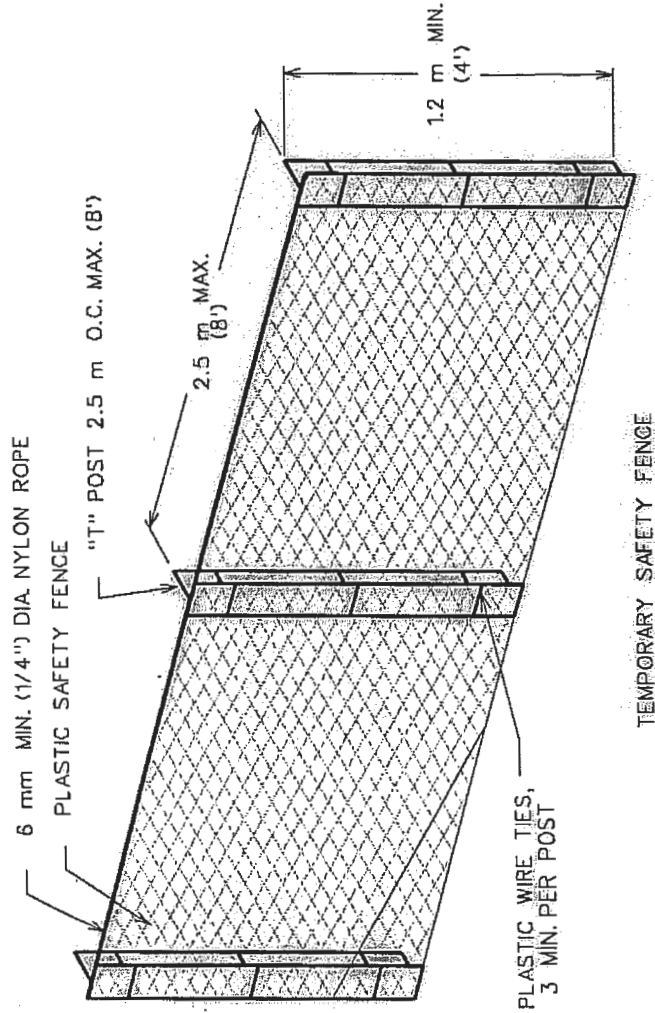

TEMPORARY SAFETY FENCE

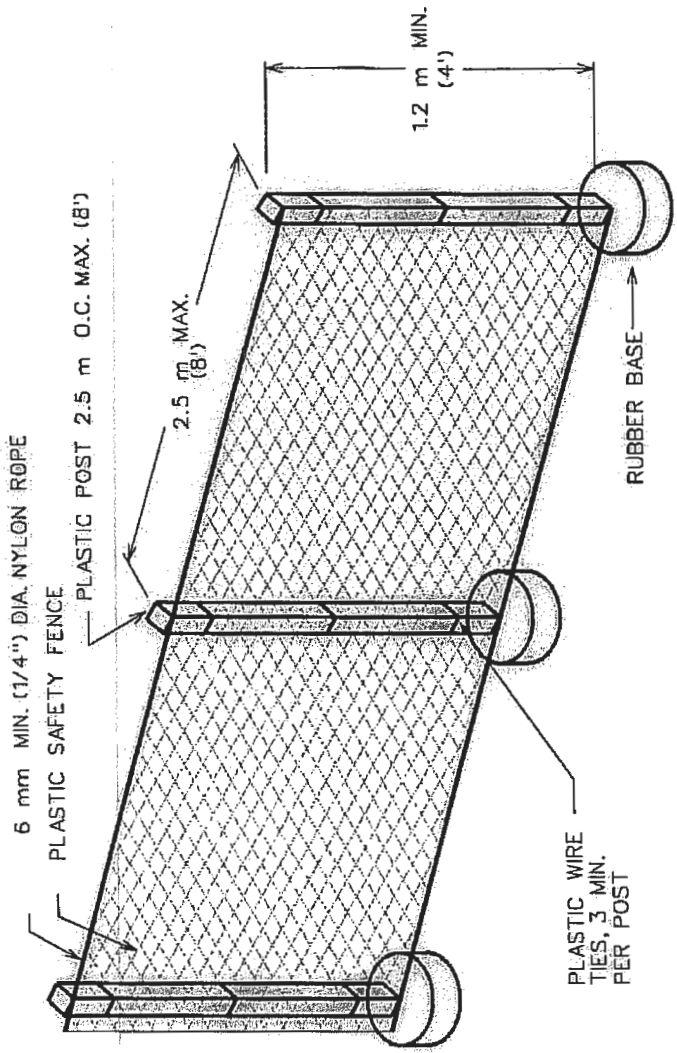

PORTABLE SAFETY FENCE

|  |   |
|--|---|
| CITY OF AUSTIN<br>DEPARTMENT OF PUBLIC WORKS | SAFETY FENCE  |
| <i>B. A. Ag</i><br>4/3/09<br>ADOPTED         | THE ARCHITECT/ENGINEER ASSUMES<br>RESPONSIBILITY FOR APPROPRIATE USE<br>OF THIS STANDARD. |
| STANDARD NO.<br><b>804S-4</b><br>1 OF 9      |   |

1. SAFETY FENCE SHALL BE USED TO PROTECT ALL EXCAVATIONS IN THE RIGHT-OF-WAY.
2. SAFETY FENCES SHALL BE USED TO SEPARATE CONSTRUCTION ACTIVITIES FROM PEDESTRIAN.
3. ALL SAFETY FENCING SHALL BE PLASTIC, 1,200 mm (48") MINIMUM HEIGHT AND ORANGE IN COLOR.
4. SAFETY FENCE USED WITHIN THE ROADWAY SHALL BE REFLECTORIZED WITH A MINIMUM OF TWO (2) STRIPS OF RETROREFLECTIVE MATERIAL, A MINIMUM OF 25 mm (1") WIDE, THE LENGTH OF THE FENCE OR DELINEATED BY CHANNELIZING DEVICES.
5. SAFETY FENCE USED TO SEPARATE SIDEWALKS FROM CONSTRUCTION ACTIVITIES SHALL HAVE MINIMUM ENCROACHMENT TO THE SIDEWALK.
6. AS A MINIMUM, SAFETY FENCING IS REQUIRED IN AREAS ADJACENT TO EXCAVATIONS GREATER THAN OR EQUAL TO 150 mm (6").
7. SAFETY FENCING SHALL BE PAID FOR UNDER ITEM 803S, 'BARRICADES, SIGNS AND TRAFFIC HANDLING', PAY ITEM NO. 803S-SF.
8. PORTABLE SAFETY FENCE MOUNTS SHALL BE APPROVED BY THE TRANSPORTATION DIVISION PRIOR TO CONSTRUCTION.

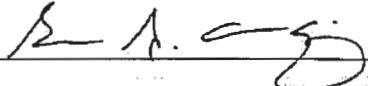
|  |  |              |        |        |
|--|--|--------------|--------|--------|
| CITY OF AUSTIN<br>DEPARTMENT OF PUBLIC WORKS   | SAFETY FENCE   |              |        |        |
| <br>4/3/09<br>ADOPTED | THE ARCHITECT/ENGINEER ASSUMES<br>RESPONSIBILITY FOR APPROPRIATE USE<br>OF THIS STANDARD. <table border="1" style="float: right; margin-top: 10px;"> <tr> <td style="padding: 2px;">STANDARD NO.</td> </tr> <tr> <td style="text-align: center; padding: 2px;">804S-4</td> </tr> <tr> <td style="text-align: center; padding: 2px;">2 OF 9</td> </tr> </table> | STANDARD NO. | 804S-4 | 2 OF 9 |
| STANDARD NO.   |  |              |        |        |
| 804S-4   |  |              |        |        |
| 2 OF 9   |  |              |        |        |

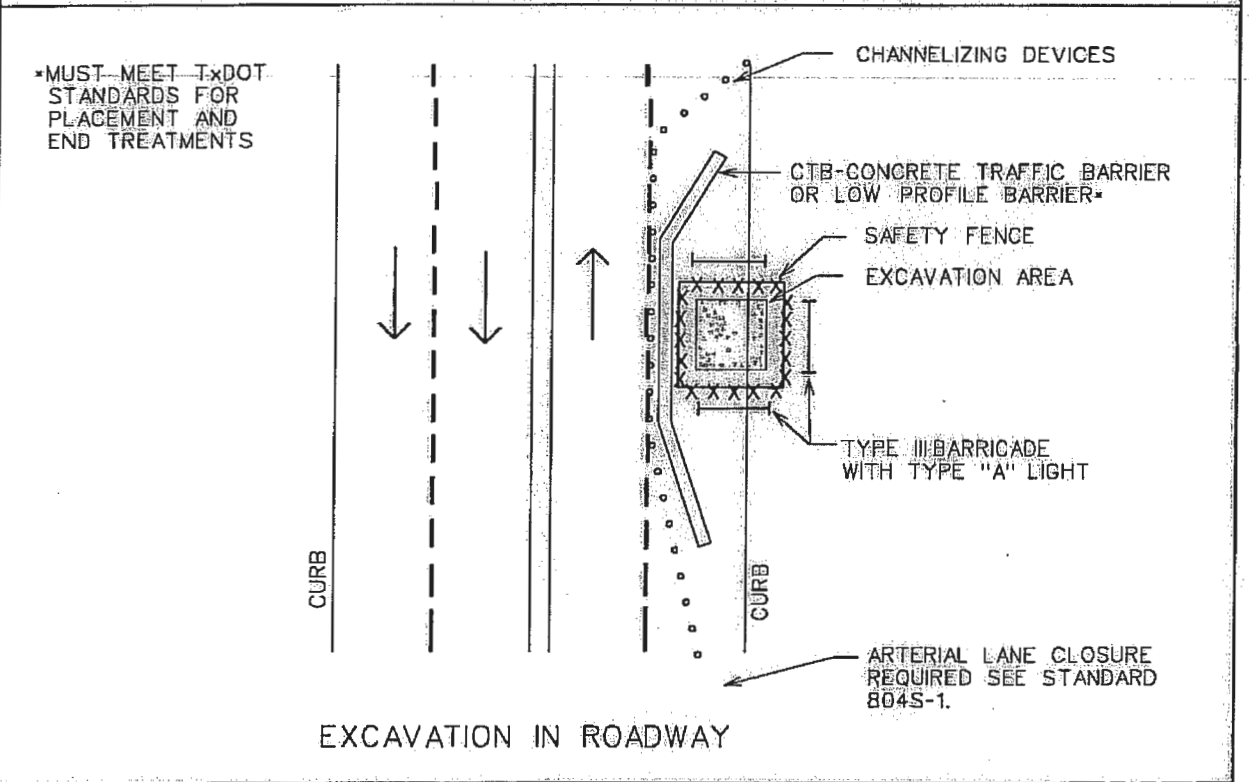
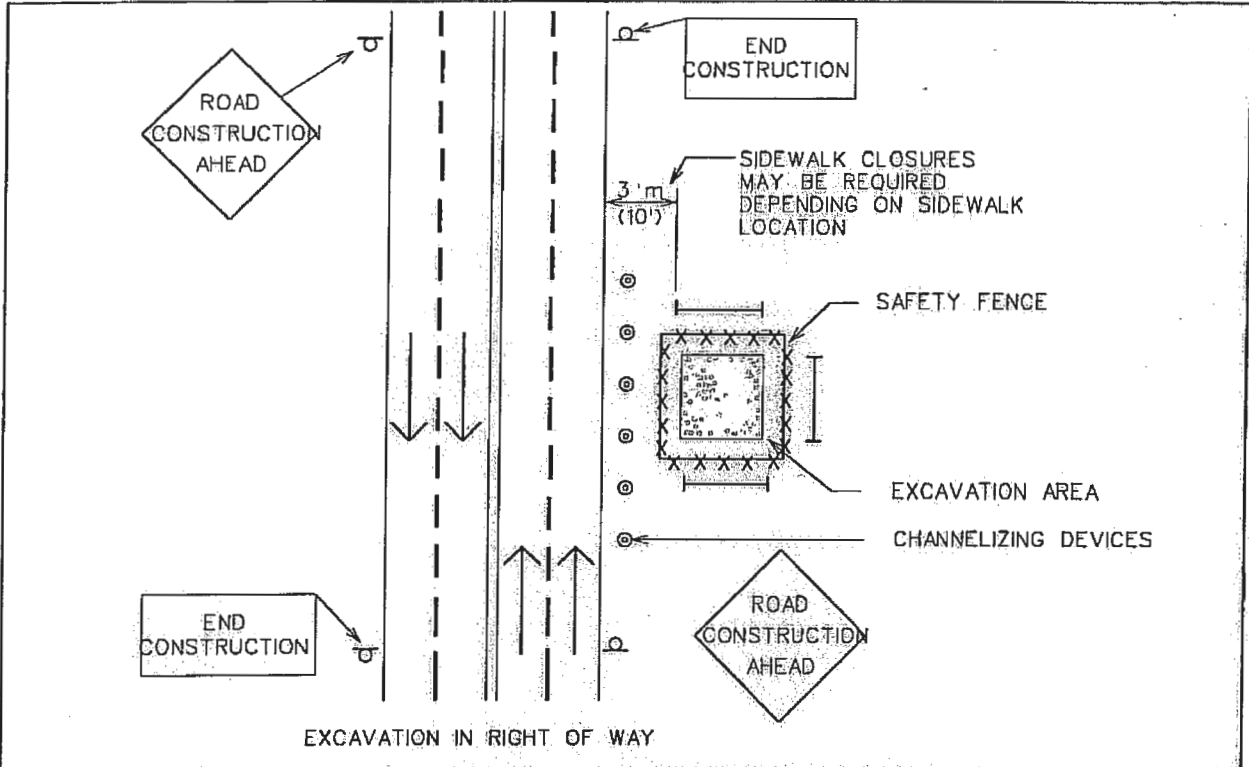

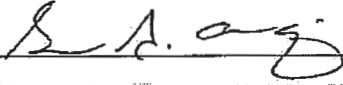
|   |                   |   |
|---|-------------------|---|
| CITY OF AUSTIN<br>DEPARTMENT OF PUBLIC WORKS  | LARGE EXCAVATION  |   |
|  | 4/3/09<br>ADOPTED | THE ARCHITECT/ENGINEER ASSUMES<br>RESPONSIBILITY FOR APPROPRIATE USE<br>OF THIS STANDARD. |
|   |                   | STANDARD NO.<br><b>804S-4</b><br>3 OF 9   |

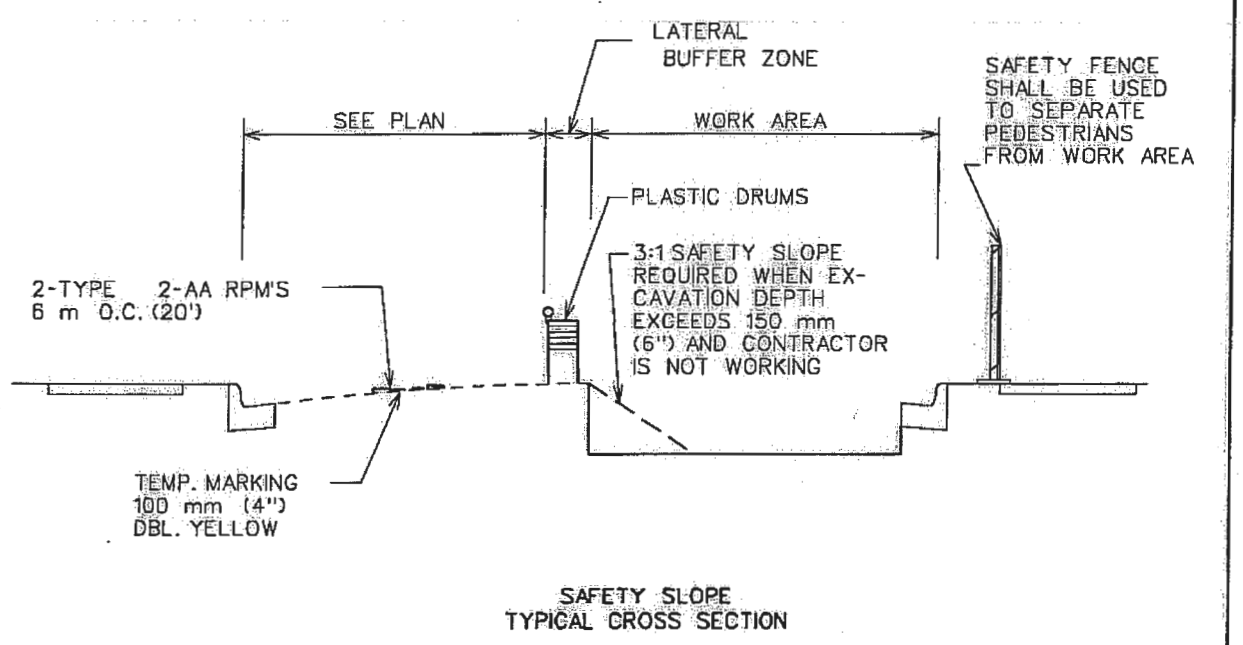
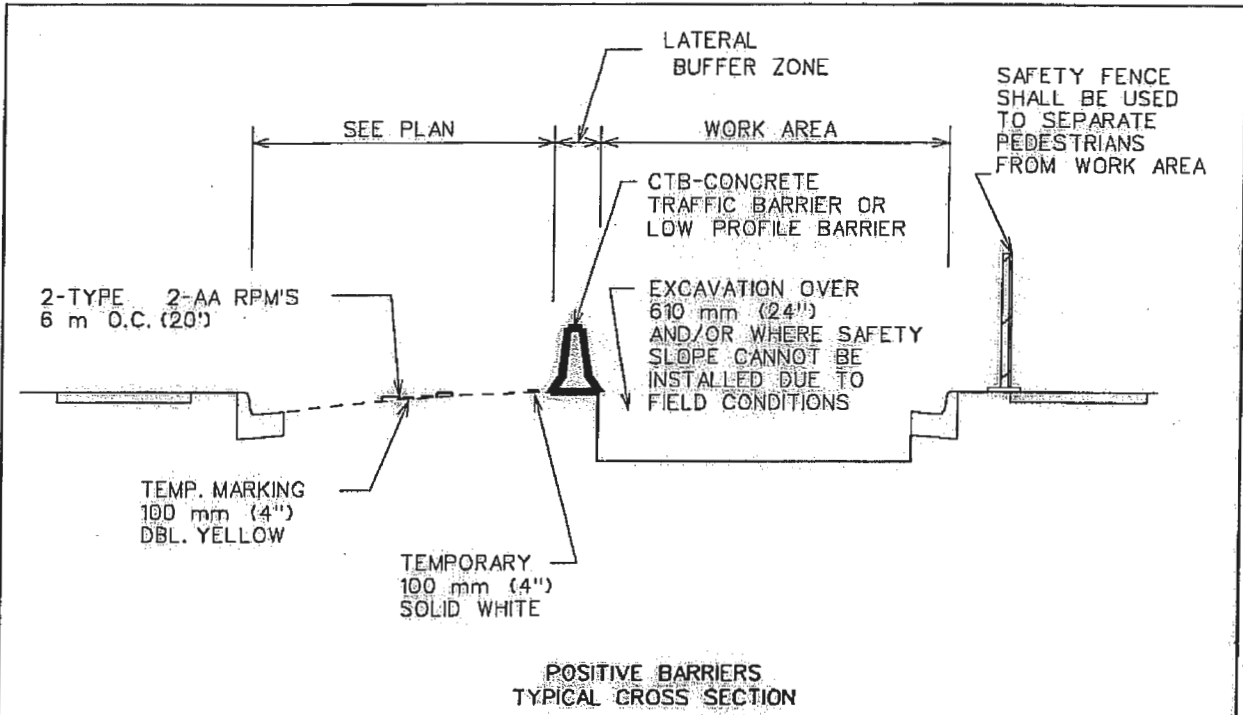

|  |  |  |
|--|--|--|
| <p>CITY OF AUSTIN<br/>DEPARTMENT OF PUBLIC WORKS</p> | <p>WORK AREA PROTECTION</p>  |  |
| <p><i>A. A. G. 4/3/09</i><br/>ADOPTED</p>            | <p>THE ARCHITECT/ENGINEER ASSUMES RESPONSIBILITY FOR APPROPRIATE USE OF THIS STANDARD.</p> | <p>STANDARD NO.<br/><b>804S-4</b><br/>4 OF 9</p> |

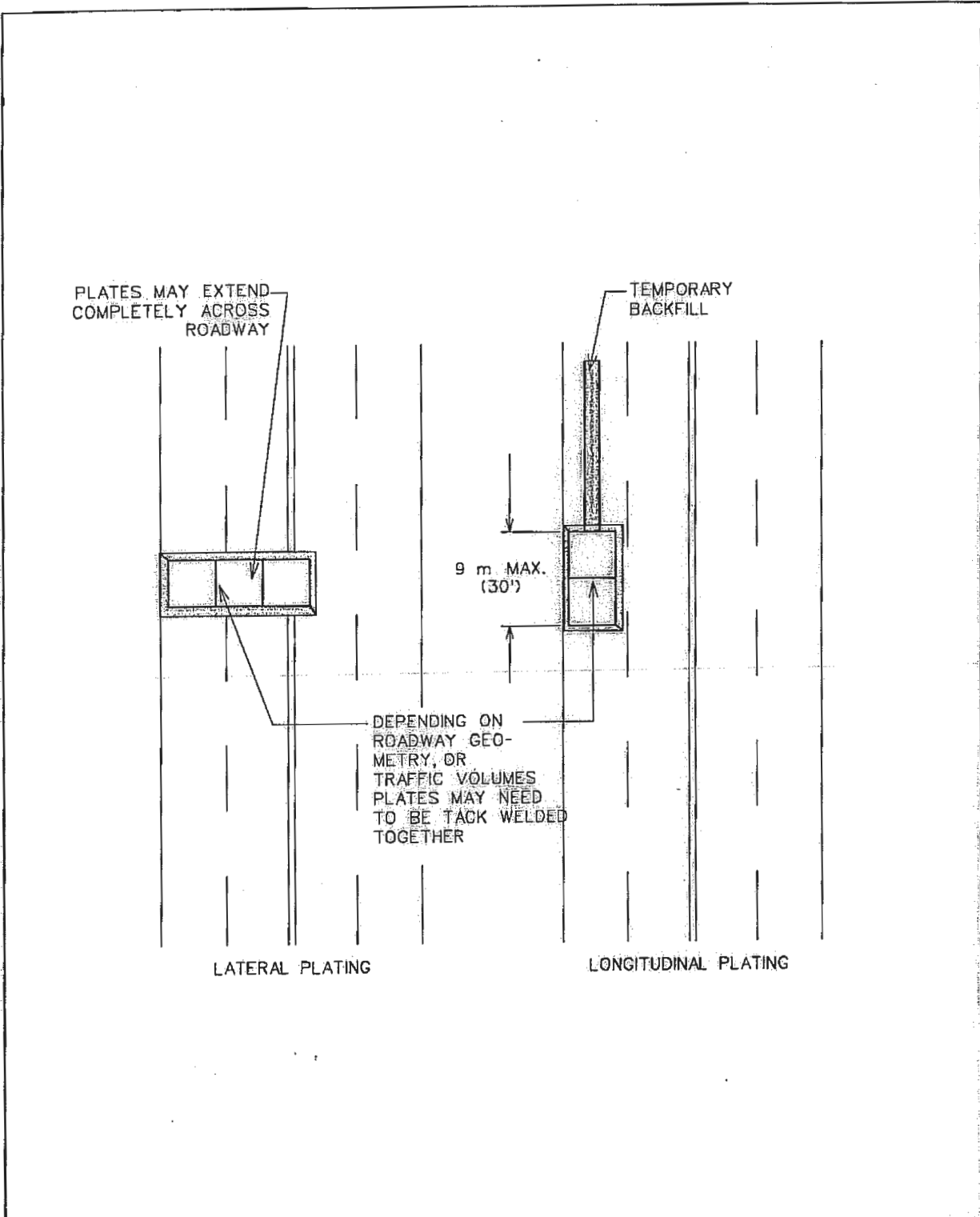

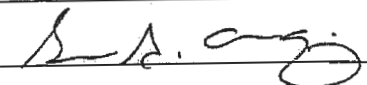
|   |                   |                  |
|---|-------------------|------------------|
| CITY OF AUSTIN<br>DEPARTMENT OF PUBLIC WORKS  | STEEL PLATING     | STANDARD NO.     |
|  | 4/3/09<br>ADOPTED | 804S-4<br>5 OF 9 |
| THE ARCHITECT/ENGINEER ASSUMES RESPONSIBILITY FOR APPROPRIATE USE OF THIS STANDARD. |                   |                  |

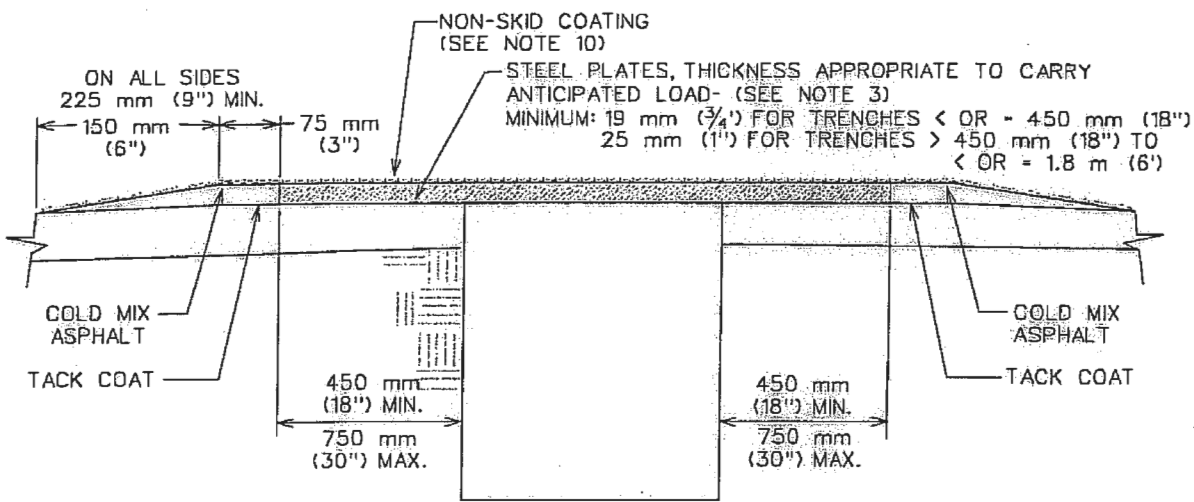

TYPICAL CROSS SECTION

CASE I- LOW TRAFFIC VOLUME/LIMITED IN-SERVICE TIME

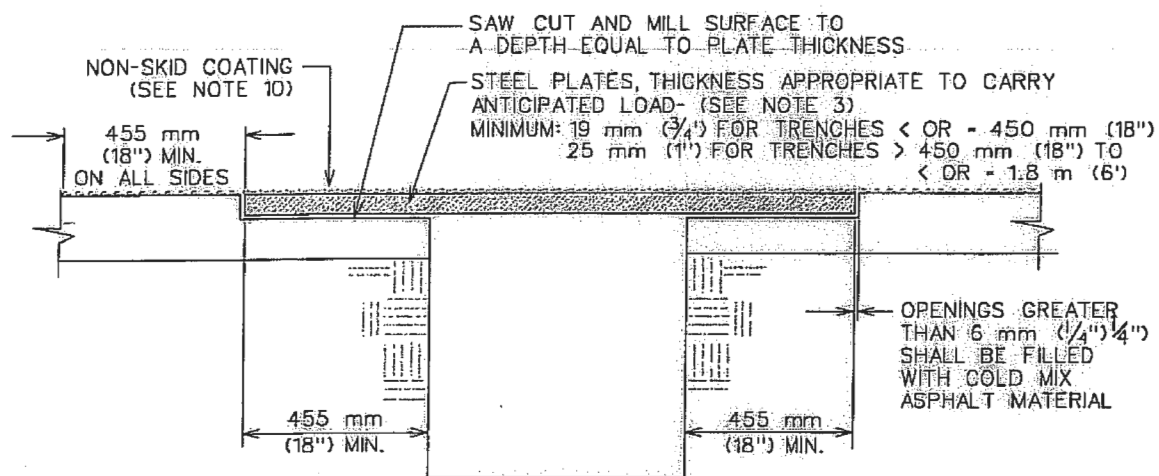

TYPICAL CROSS SECTION

CASE II- EXTENDED IN-SERVICE PLATING AND/OR HEAVILY-TRAFFICKED ROADS/STREETS (HMAC PAVEMENTS ONLY)

|  |  |                          |
|--|--|--------------------------|
| <p>CITY OF AUSTIN<br/>DEPARTMENT OF PUBLIC WORKS</p> | <p>STEEL PLATING</p>   | <p>STANDARD NO.</p>      |
| <p><i>B. A. Og</i> 4/3/09<br/>ADOPTED</p>            | <p>THE ARCHITECT/ENGINEER ASSUMES RESPONSIBILITY FOR APPROPRIATE USE OF THIS STANDARD.</p> | <p>804S-4<br/>6 OF 9</p> |

NOTES:

1. WHERE TRAFFIC MUST CROSS TRENCHES, THE CONTRACTOR SHALL PROVIDE SUITABLE BRIDGES.
2. THE USE OF STEEL PLATES SHALL BE APPROVED BY THE RIGHT OF WAY MANAGEMENT DIVISION OF WATERSHED PROTECTION AND DEVELOPMENT DEPARTMENT PRIOR TO INITIATION OF CONSTRUCTION.
3. THE THICKNESS OF PLATES FOR TRENCH WIDTHS EXCEEDING 1.8 m (6') SHALL BE ESTABLISHED IN AN ANALYSIS COMPLETED BY A LICENSED PROFESSIONAL ENGINEER, REGISTERED IN THE STATE OF TEXAS. THE ANALYSIS SHALL BE BASED ON HS-20 TRAFFIC LOADING WITH A MAXIMUM PLATE DEFLECTION OF 50 mm (1/2") WHEN EXPERIENCING SAID LOADING. FOR SITUATIONS WHERE MULTIPLE LAYERS OF PLATES (OR STACKED PLATES) ARE TO BE EMPLOYED, THE SEAMS (IE THE INTER-FACE BETWEEN PLACED SIDE-BY-SIDE) OF THE UPPER LAYER SHALL BE PLACED PERPENDICULAR TO THE SEAMS OF THE UNDERLYING PLATES.
4. WHEN APPROVED, THE TYPE OF PLATE INSTALLATION SHALL BE BASED ON THE ANTICIPATED LENGTH OF TIME THE PLATE WILL BE IN SERVICE:  
 CASE I: A CASE I INSTALLATION SHALL APPLY FOR NO LONGER THAN A 2 WEEK PERIOD.  
 CASE II: A CASE II INSTALLATION SHALL APPLY FOR NO LONGER THAN 2 WEEK PERIOD.
5. THE TOPSIDE OF THE STEEL PLATE SHALL BE FLAT AND FREE OF ANY CLIPS, CHAINS, ATTACHMENTS, WELDMENTS OR SURFACE IRREGULARITIES.
6. PLATES WITH A PERMANENT DISPLACEMENT (I.E. DISPLACEMENT ANYWHERE ON THE SURFACE OF THE PLATE WITH RESPECT TO A PLANE FORMED BY THE OUTSIDE EDGES) THAT EXCEEDS 12 mm (1/2") SHALL NOT BE USED FOR PLATING PURPOSES. PLATES THAT DEVELOP A PERMANENT DISPLACEMENT EXCEEDING 12 mm (1/2") DURING SERVICE SHALL BE REMOVED AND REPLACED.
7. THE PLATES SHALL BE PROVIDED WITH APPROPRIATE NUMBER OF KEYHOLE SLOTS OR CIRCULAR HOLES FOR HANDLING, LIFTING, INSTALLATION AND REMOVAL PURPOSES.
8. THE CONTRACTOR SHOULD AVOID USING A LONG SERIES OF PLATES THAT RUN PARALLEL TO VEHICULAR TRAFFIC WHEELS PATHS.
9. ADDITIONAL METHODS OF SECURING PLATES MAY BE REQUIRED DEPENDING ON FIELD CONDITIONS.
10. FOR PLATES 1.8 M (6') OR GREATER IN DIRECTION OF TRAFFIC, A NON-SKID COATING SHOULD BE APPLIED TO THE ENTIRE SURFACE AREA OF ALL PLATES, AS WELL AS ADJACENT AREAS. THE NON-SKID COATING SHALL BE TCA (TEXTURED COATING OF AMERICA, INC.) STRATA-GRIP DECK COATING SYSTEM; SLIPFIX, INC. SPS (SLIP PROTECTION SURFACE) OR AN EQUIVALENT PRODUCT APPROVED BY THE ENGINEER OR DESIGNATED REPRESENTATIVE.

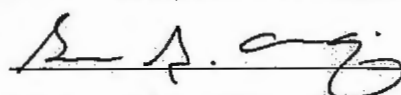
|  |   |              |        |        |
|--|---|--------------|--------|--------|
| CITY OF AUSTIN<br>DEPARTMENT OF PUBLIC WORKS   | STEEL PLATING   |              |        |        |
| <br>4/3/09<br>ADOPTED | THE ARCHITECT/ENGINEER ASSUMES<br>RESPONSIBILITY FOR APPROPRIATE USE<br>OF THIS STANDARD. <table style="float: right; border: none;"> <tr> <td style="text-align: right;">STANDARD NO.</td> </tr> <tr> <td style="text-align: right; font-size: 24pt;">804S-4</td> </tr> <tr> <td style="text-align: right;">7 OF 9</td> </tr> </table> | STANDARD NO. | 804S-4 | 7 OF 9 |
| STANDARD NO.   |   |              |        |        |
| 804S-4   |   |              |        |        |
| 7 OF 9   |   |              |        |        |

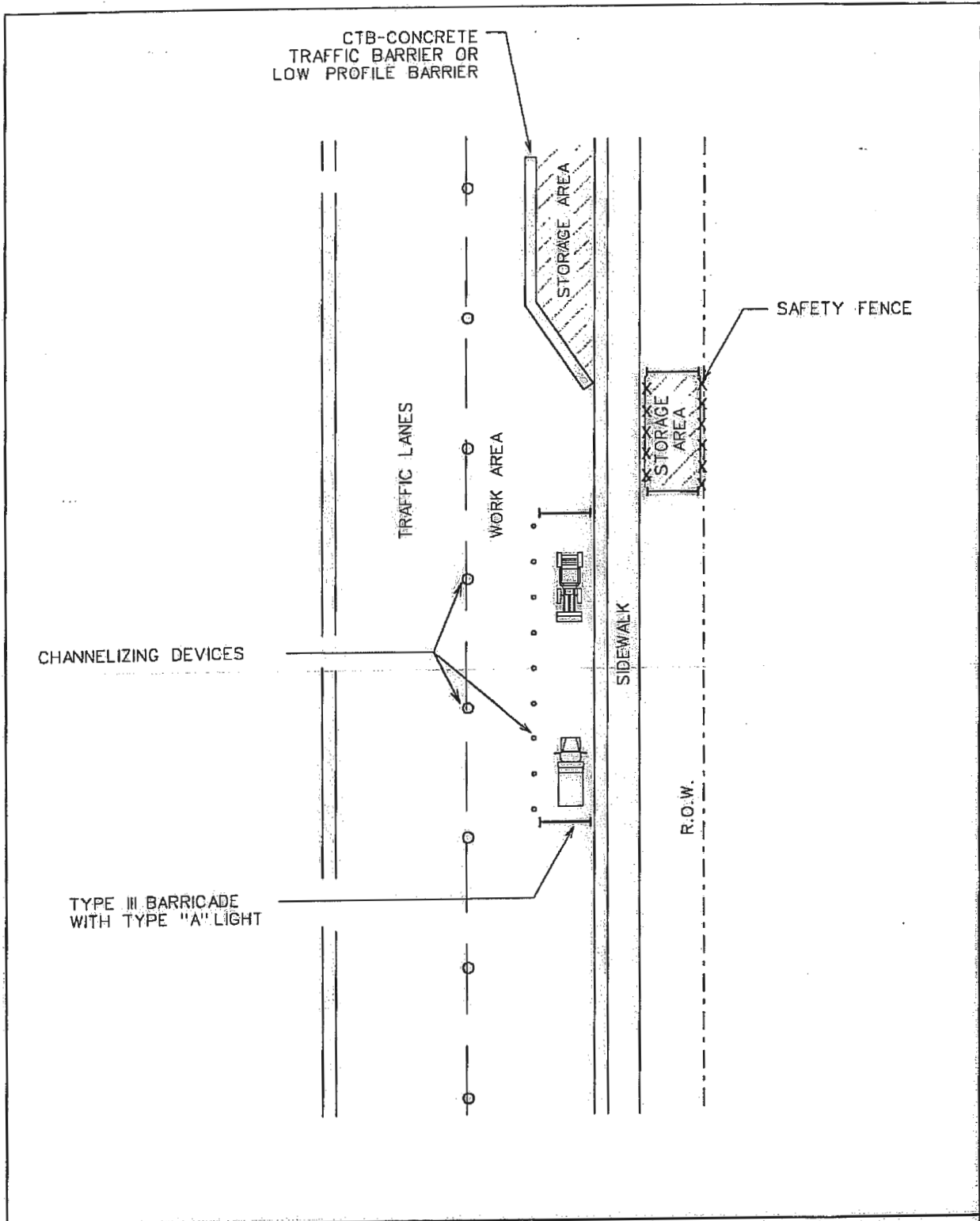

CITY OF AUSTIN  
DEPARTMENT OF PUBLIC WORKS

MATERIAL AND EQUIPMENT STORAGE

*[Handwritten Signature]* 4/3/09  
ADOPTED

THE ARCHITECT/ENGINEER ASSUMES  
RESPONSIBILITY FOR APPROPRIATE USE  
OF THIS STANDARD.

STANDARD NO.  
**804S-4**  
8 OF 9

1. STORAGE OF EQUIPMENT AND MATERIALS SHALL BE RESTRICTED TO LOCATIONS WHERE DRIVER SIGHT DISTANCES TO TRAFFIC, PEDESTRIANS, BUSINESSES AND SIDE STREET INTERSECTIONS ARE NOT OBSTRUCTED OR WHERE AN UNSIGHTLY APPEARANCE, AS DETERMINED BY THE ENGINEER, WILL NOT EXIST.
2. EQUIPMENT MUST BE PARKED AS FAR AWAY FROM THE TRAVELWAYS AS PRACTICAL.
3. TOTAL AREA USED FOR EQUIPMENT STORAGE SHALL BE KEPT TO A MINIMUM.
4. ALL MATERIALS STORED IN THE RIGHT-OF-WAY MUST BE MAINTAINED IN A NEAT AND ORGANIZED MANNER.
5. MATERIALS STORED MAY NOT BE MORE THAN 915 mm (36") IN HEIGHT.
6. ALL MATERIALS STORED MUST BE USED WITHIN THREE (3) DAYS.

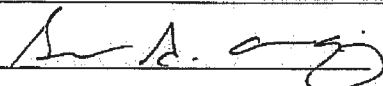
|  |   |                                  |
|--|---|----------------------------------|
| CITY OF AUSTIN<br>DEPARTMENT OF PUBLIC WORKS   | MATERIAL AND EQUIPMENT STORAGE  |                                  |
| <br>4/3/09<br>ADOPTED | THE ARCHITECT/ENGINEER ASSUMES<br>RESPONSIBILITY FOR APPROPRIATE USE<br>OF THIS STANDARD. | STANDARD NO.<br>804S-4<br>9 OF 9 |

TRENCH REPAIR IN ASPHALTIC SURFACE OVER FLEXIBLE BASE  
(UCM SECTION 5.8.0)

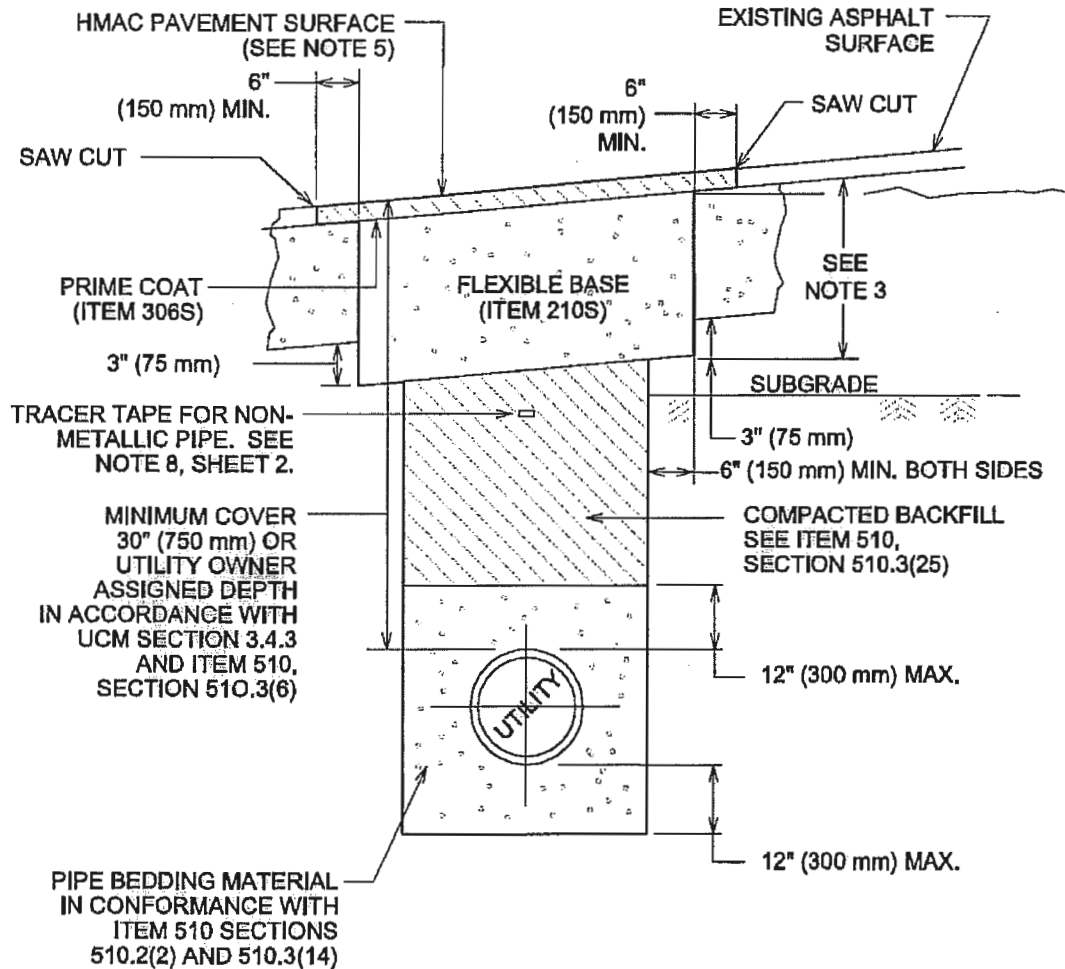

|   |  |                                  |
|---|--|----------------------------------|
| <p>CITY OF AUSTIN<br/>DEPARTMENT OF PUBLIC WORKS</p>      | <p>FLEXIBLE BASE WITH ASPHALT SURFACE<br/>TRENCH REPAIR-EXISTING PAVEMENT</p>                      | <p>STANDARD NO.</p>              |
| <p><i>Kris Burckhard</i> <i>Jan 14/11</i><br/>ADOPTED</p> | <p>THE ARCHITECT/ENGINEER ASSUMES<br/>RESPONSIBILITY FOR APPROPRIATE USE<br/>OF THIS STANDARD.</p> | <p><b>1100S-2</b><br/>1 OF 2</p> |

**NOTES:**

1. THE EXISTING PAVING SURFACE SHALL BE SAW CUT IN A STRAIGHT LINE, A MINIMUM OF 12" (300 mm) WIDER THAN UNDISTURBED SIDES OF THE TRENCH AND SYMMETRICAL ABOUT THE CENTER LINE OF THE EXCAVATION.
2. IF EXCAVATION AREA IS OPEN FOR TEMPORARY PUBLIC USE, THE SURFACE SHALL BE MAINTAINED LEVEL WITH ADJACENT RIDING SURFACE WITH COLD MIX AC OR TEMPORARY HMAC. TEMPORARY MIX SHALL BE PLACED OVER FLEXIBLE BASE.
3. ROAD BASE SHALL BE REPLACED IN KIND WITH BASE THICKNESS EQUAL TO EXISTING BASE THICKNESS PLUS 3" (75 mm), BUT IN NO CASE LESS THAN 12" (300 mm).
4. DAMAGED PAVEMENT OUTSIDE THE TRENCH CUT SHALL BE REMOVED AND REPLACED WITH A BASE THICKNESS OF 10" (250 mm) OR A THICKNESS MATCHING EXISTING, WHICHEVER IS GREATER.
5. REPLACEMENT AC SURFACE LAYER SHALL BE OF THE TYPE AND THICKNESS BASED ON FUNCTIONAL CLASSIFICATION.
  - a) MIN. 2" (50 mm) HMAC TYPE "D" FOR TRENCH REPAIR IN LOCAL/RESIDENTIAL STREETS.
  - b) MIN. 3" (75 mm) HMAC TYPE "C" FOR TRENCH REPAIR IN COLLECTOR/ARTERIAL STREETS.
 SEE ITEM 340S, SECTION 340S.4.
6. CLASS "J" PC CONCRETE (ITEM 403S) OR CONTROLLED LOW STRENGTH MATERIAL (CLSM) MAY BE SUBSTITUTED IN THESE REPAIRS FOR THE FLEXIBLE BASE AND COMPACTED BACKFILL. PC CONCRETE GREATER THAN A 2 SACK MIX WILL NOT BE ALLOWED.
7. TACK COAT ALL EXPOSED EDGES AND SURFACES (SPEC ITEM 307S).
8. AS PER CITY OF AUSTIN STANDARD SPECIFICATION 510, SECTION 510.2(8)(K)5, FOR ALL NON-METALLIC PIPE, DIRECTLY ABOVE THE CENTERLINE OF THE PIPE AND A MINIMUM OF 12" (300 mm) BELOW THE SUBGRADE, OR A MINIMUM OF 18" (450 mm) BELOW FINISHED GRADE ON AREAS OUTSIDE THE LIMITS OF PAVEMENT, SHALL BE PLACED INDUCTIVE TRACER TAPE IN ACCORDANCE WITH THE MANUFACTURER'S REQUIREMENTS. THE TAPE SHALL BE ENCASED IN A PROTECTIVE, INERT, PLASTIC JACKET AND COLOR CODED IN ACCORDANCE WITH APWA UNIFORM COLOR CODE.

|  |  |   |
|--|--|---|
| <p style="text-align: center;">CITY OF AUSTIN<br/>DEPARTMENT OF PUBLIC WORKS</p> | <p style="text-align: center;"><b>FLEXIBLE BASE WITH ASPHALT SURFACE<br/>TRENCH REPAIR-EXISTING PAVEMENT</b></p> |   |
| <p><i>Keri Burchard - Gray</i> 4/4/11<br/>ADOPTED</p>                            | <p>THE ARCHITECT/ENGINEER ASSUMES<br/>RESPONSIBILITY FOR APPROPRIATE USE<br/>OF THIS STANDARD.</p>               | <p style="text-align: center;">STANDARD NO.<br/><b>1100S-2</b><br/>2 OF 2</p> |

TRENCH REPAIR IN EXISTING PAVEMENTS  
(UCM SECTION 5.5.10, 5.5.11, & 5.5.12)

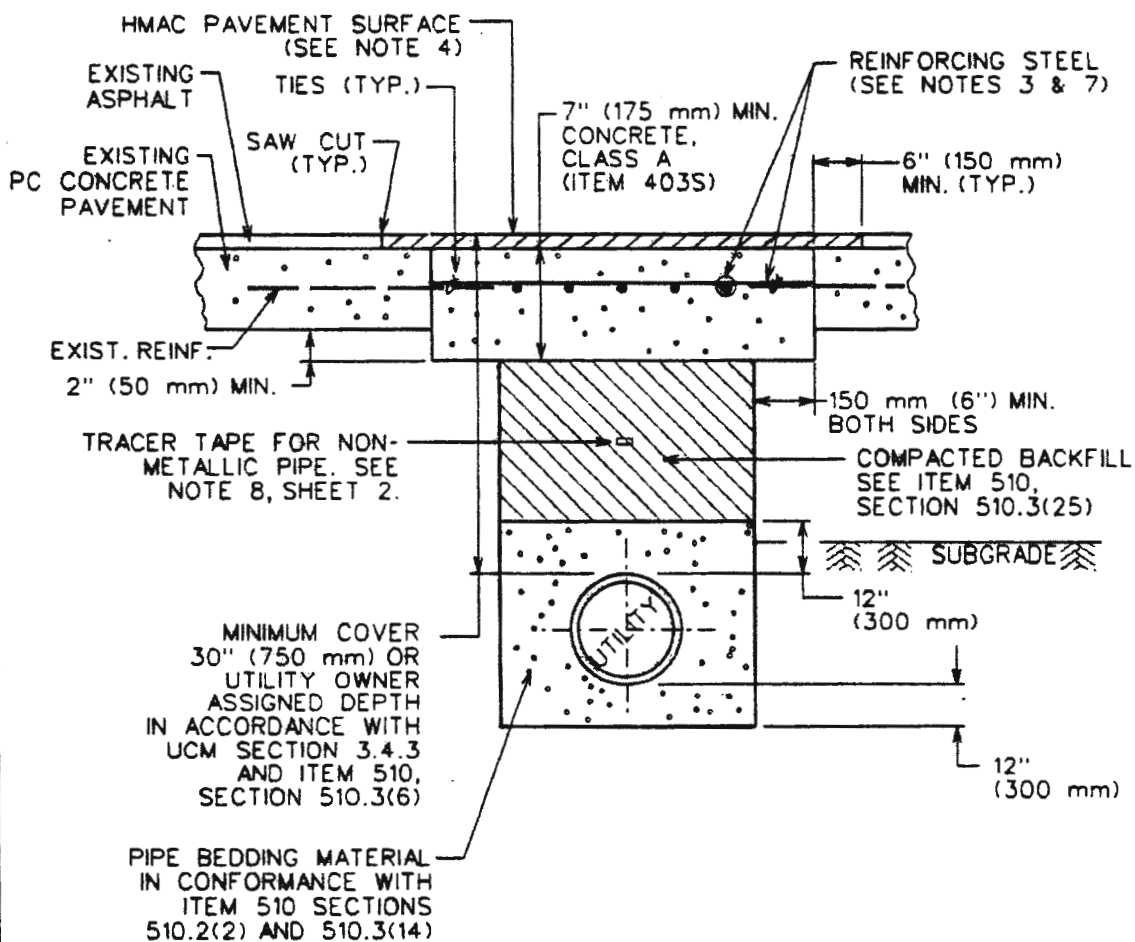

|  |   |
|--|---|
| CITY OF AUSTIN<br>DEPARTMENT OF PUBLIC WORKS | ASPHALT OVERLAY OF REINFORCED AND<br>NON-REINFORCED PC PVT.-TRENCH REPAIR                 |
| <i>Bill Anderson</i> 9/14/05<br>ADOPTED      | THE ARCHITECT/ENGINEER ASSUMES<br>RESPONSIBILITY FOR APPROPRIATE USE<br>OF THIS STANDARD. |
| STANDARD NO.<br><b>1100S-3</b><br>1 OF 2     |   |

NOTES:

1. EXISTING REINFORCED CONCRETE SHALL BE SAW CUT TO A MINIMUM DEPTH OF 1/2" (40 mm) AT A MINIMUM DISTANCE OF 6" (150 mm) BACK OF THE VERTICAL WALL OF THE UTILITY TRENCH.
2. REPLACEMENT REINFORCED CONCRETE SHALL BE CLASS A AND SHALL MATCH EXISTING FINISH AND THICKNESS, BUT THE THICKNESS SHALL NOT BE LESS THAN 7" (175 mm).
3. REINFORCING STEEL IN THE REPLACEMENT SLAB SHALL BE AT LEAST #5 (15M) BARS. REINFORCING STEEL SHALL BE LAP SPLICED ACCORDING TO ITEM NO. 406S. IF LENGTH OF LAP CAN NOT BE ACHIEVED, BARS SHALL BE OVERLAPPED AND WELDED A MINIMUM LENGTH OF 6" (150 mm).
4. IF EXISTING PAVEMENT SECTION HAS AN ASPHALT SURFACE THE FOLLOWING APPLIES: REPLACEMENT AC SURFACE LAYER SHALL BE OF THE TYPE AND THICKNESS BASED ON FUNCTIONAL CLASSIFICATION.
  - a) MIN. 2" (50 mm) HMAC TYPE "D" FOR TRENCH REPAIR IN LOCAL/RESIDENTIAL STREETS.
  - b) MIN. 3" (75 mm) HMAC TYPE "C" FOR TRENCH REPAIR IN COLLECTOR/ARTERIAL STREETS.
 SEE ITEM 340S, SECTION 340S.4.
5. CLASS "J" PC CONCRETE (ITEM 403S) OR CONTROLLED LOW STRENGTH MATERIAL (CLSM) MAY BE SUBSTITUTED IN THESE REPAIRS FOR THE FLEXIBLE BASE AND COMPACTED BACKFILL. PC CONCRETE GREATER THAN A 2 SACK MIX WILL NOT BE ALLOWED.
6. TACK COAT (ITEM 307S) ALL EXPOSED EDGES AND SURFACES.
7. ON EXISTING PC CONCRETE PAVEMENT WITHOUT REINFORCING STEEL, USE 4" TO 6" (100 mm TO 150 mm), #5 (15M) DOWELS AT 12" (300 mm) ON CENTER FOR PAVEMENT THICKNESS 6" (150 mm) OR GREATER.
8. AS PER CITY OF AUSTIN STANDARD SPECIFICATION 510, SECTION 510.2(8)(K)5, FOR ALL NON-METALLIC PIPE, DIRECTLY ABOVE THE CENTERLINE OF THE PIPE AND A MINIMUM OF 12" (300 mm) BELOW THE SUBGRADE, OR A MINIMUM OF 18" (450 mm) BELOW FINISHED GRADE ON AREAS OUTSIDE THE LIMITS OF PAVEMENT, SHALL BE PLACED INDUCTIVE TRACER TAPE IN ACCORDANCE WITH THE MANUFACTURER'S REQUIREMENTS. THE TAPE SHALL BE ENCASED IN A PROTECTIVE, INERT, PLASTIC JACKET AND COLOR CODED IN ACCORDANCE WITH APWA UNIFORM COLOR CODE.

|   |   |              |         |        |
|---|---|--------------|---------|--------|
| CITY OF AUSTIN<br>DEPARTMENT OF PUBLIC WORKS  | ASPHALT OVERLAY OF REINFORCED AND<br>NON-REINFORCED PC PVT.-TRENCH REPAIR   |              |         |        |
|  9/14/05<br>/ADOPTED | THE ARCHITECT/ENGINEER ASSUMES<br>RESPONSIBILITY FOR APPROPRIATE USE<br>OF THIS STANDARD. <table border="1" data-bbox="1185 1780 1427 1875"> <tr> <td data-bbox="1185 1780 1427 1806">STANDARD NO.</td> </tr> <tr> <td data-bbox="1185 1806 1427 1848">1100S-3</td> </tr> <tr> <td data-bbox="1185 1848 1427 1875">2 OF 2</td> </tr> </table> | STANDARD NO. | 1100S-3 | 2 OF 2 |
| STANDARD NO.  |   |              |         |        |
| 1100S-3   |   |              |         |        |
| 2 OF 2  |   |              |         |        |

REPAIR OF FULL DEPTH ASPHALTIC CONCRETE (UCM SECTION 5.5.13)

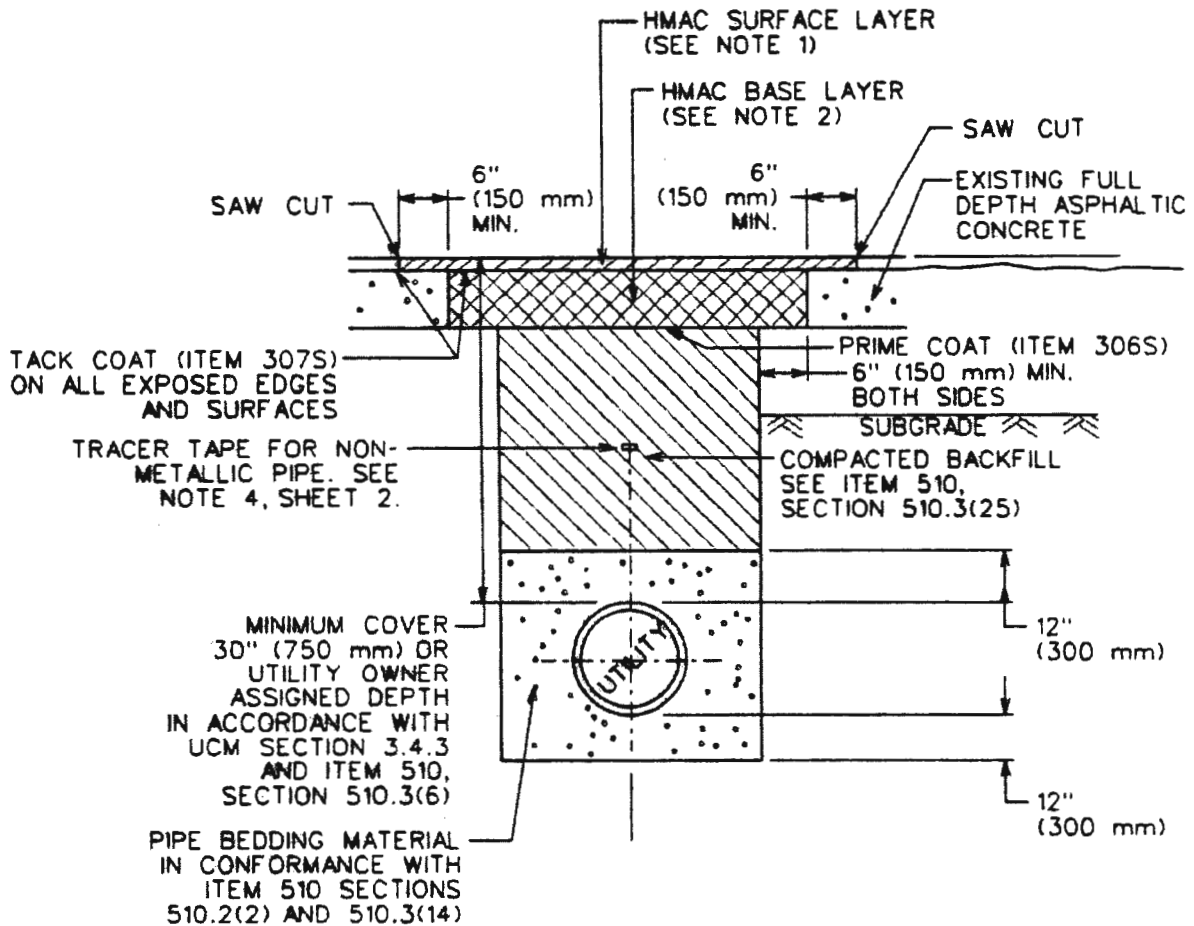

|  |  |  |
|--|--|--|
| <p>CITY OF AUSTIN<br/>DEPARTMENT OF PUBLIC WORKS</p> | <p>FULL DEPTH ASPHALTIC CONCRETE<br/>PAVEMENT TRENCH REPAIR</p>                                    |  |
| <p><i>Bill Adams</i> 9/14/05<br/>ADOPTED</p>         | <p>THE ARCHITECT/ENGINEER ASSUMES<br/>RESPONSIBILITY FOR APPROPRIATE USE<br/>OF THIS STANDARD.</p> | <p>STANDARD NO.<br/>1100S-5<br/>1 OF 2</p> |

NOTES:

1. REPLACEMENT AC SURFACE LAYER SHALL BE OF THE TYPE AND THICKNESS BASED ON FUNCTIONAL CLASSIFICATION.

a) MIN. 2" (50 mm) HMA TYPE "D" FOR TRENCH REPAIR IN LOCAL/RESIDENTIAL STREETS.

b) MIN. 3" (75 mm) HMA TYPE "C" FOR TRENCH REPAIR IN COLLECTOR/ARTERIAL STREETS.

SEE ITEM 340S, SECTION 340S.4.

2. THE COMBINED THICKNESS OF THE REPLACEMENT AC SURFACE AND BASE LAYERS SHALL MATCH THE THICKNESS OF EXISTING FULL DEPTH AC LAYER. HOWEVER, THE REPLACEMENT AC BASE LAYER SHALL BE A MINIMUM THICKNESS OF 6" (150 mm) OF TYPE A OR B HMA. A BASE LAYER TYPE THAT MATCHES THE NEW HMA SURFACE LAYER (SEE NOTE 1) MAY BE USED, IF THE TOTAL REPAIR AREA IS LESS THAN 300 SQUARE YARDS (250 SQUARE METERS).

3. CLASS "J" PC CONCRETE (ITEM 403S) OR CONTROLLED LOW STRENGTH MATERIAL (CLSM) MAY BE SUBSTITUTED IN THESE REPAIRS FOR THE FLEXIBLE BASE AND COMPACTED BACKFILL. PC CONCRETE GREATER THAN A 2 SACK MIX WILL NOT BE ALLOWED.

4. AS PER CITY OF AUSTIN STANDARD SPECIFICATION 510, SECTION 510.2(B)(K)5, FOR ALL NON-METALLIC PIPE, DIRECTLY ABOVE THE CENTERLINE OF THE PIPE AND A MINIMUM OF 12" (300 mm) BELOW THE SUBGRADE, OR A MINIMUM OF 18" (450 mm) BELOW FINISHED GRADE ON AREAS OUTSIDE THE LIMITS OF PAVEMENT, SHALL BE PLACED INDUCTIVE TRACER TAPE IN ACCORDANCE WITH THE MANUFACTURER'S REQUIREMENTS. THE TAPE SHALL BE ENCASED IN A PROTECTIVE, INERT, PLASTIC JACKET AND COLOR CODED IN ACCORDANCE WITH APWA UNIFORM COLOR CODE.

|  |   |
|--|---|
| CITY OF AUSTIN<br>DEPARTMENT OF PUBLIC WORKS | FULL DEPTH ASPHALTIC CONCRETE<br>PAVEMENT TRENCH REPAIR   |
| <i>Bill Jordan</i> 9/14/05<br>ADOPTED        | THE ARCHITECT/ENGINEER ASSUMES<br>RESPONSIBILITY FOR APPROPRIATE USE<br>OF THIS STANDARD. STANDARD NO.<br>1100S-5<br>2 OF 2 |