

# 3000

## COVERED CONDUCTOR SYSTEM

### CONTAINS

- 3000-00 GENERAL INFO & COVERED TO BARE TRANSITION POLE**
- 3000-10 COVERED CONDUCTOR NOTES & INFO**
- 3000-20 WILDLIFE GUARD TYPES & NOTES**
- 3000-21 DEADEND AND WEDGE CLAMP GUARD**
- 3000-22 STIRRUP / HOT LINE CLAMP AND DISCONNECT GUARD**
- 3000-23 FUSE CUTOUT GUARD KIT**
- 3000-24 SELF-FUSING TAPE**
- 3000-30 VIBRATION DAMPER OVERVIEW**
- 3000-31 SPIRAL AND STOCKBRIDGE VIBRATION DAMPERS**

**General Information**

Austin Energy developed covered conductor system standards to enhance grid resiliency, improve system reliability, and to reduce fire risks associated with electrical infrastructure. The covered conductor system utilizes a combination of covered conductor and animal guards to reduce the potential for ignitions caused by contact with energized lines and system components, including vegetation, wildlife, and debris. The covered conductor system provides a more resilient and reliable overhead construction option than Austin Energy's typical distribution system using exposed primary conductor and components. The covered conductor system is particularly effective in areas with high vegetation density, or areas with high reliability requirements to minimize outages caused by vegetation contact, animal contact, or environmental wear.

**Covered Conductor System Approach**

**1. Use the Appropriate Covered Conductor**

- See DCS Section 3000-10 for covered conductor data and see DCS Section 1208-01 for CU covered conductor options.

**1. Use Polymer Pin-Type Insulators with Covered Tie Wires**

- Unlike bare conductors, covered conductors need specific polymer pin-type insulators with covered tie wires to accommodate the electrical properties of covered conductor. Polymer insulators extend the potential life of covered conductor systems. Covered tie wires provide proper grip and insulation, reducing the risk of damage to the conductor's covering. CUs for polymer insulators can be seen in \_\_DCS Section 1120 and CUs for covered tie wires can be seen in DCS Section 1240.

**2. Use Wildlife Guards to Create an All-Covered System**

- Splices, dead-ends, equipment bushings, fuses, and lightning arrestors must have protective covers to maintain the covered conductor system's overall insulation integrity. Exposed/energized areas would negate the purpose of a covered conductor, increasing the risk of faults or wildlife contact. Wildlife guards can be seen in DCS Section 3000-20.

**3. Use Vibration Dampeners when Required**

- Due to the higher potential for aeolian vibrations with covered conductor vs bare conductor, vibration dampeners have been added to Austin Energy's Distribution Construction Standards (DCS). These are to be used in the case of a particularly long span or to mitigate an issue with span which may be experiencing aeolian vibrations. These dampeners can be seen in DCS Section 3000-30.
- Aeolian Vibrations are more likely in covered conductor due to the uneven weight distribution of the conductor in the center with the covering around the outside, as well as due to the smooth evenly round surface of the covering on the conductor.

**4. Use Surge Arresters at All Equipment and at Other Appropriate Locations**

- Proper surge protection is critical for overhead covered conductors, as their insulated nature may alter system behavior under surge conditions. Surge arresters should be installed overhead at every primary riser, recloser, solid blade switch, on both sides, capacitor, regulator, overhead transformer, and branch line fusing locations.

**5. Covered Conductor Sag and Tension**

- Sag and tension for covered conductor differs from bare conductor. See DCS Section 1098-06 for sag and tension tables for covered conductors.

**Operational Notes**

- Covered conductors must be handled and treated as bare conductors, requiring the same safety precautions and operational protocols.
- The outer covering must be stripped at connection points to ensure proper electrical contact. This step requires precision to avoid damage to the conductor and maintain its performance.
- The installation of a covered conductor system does not eliminate the need for tree trimming to maintain clearances and prevent interference with the conductor.
- For transitions from bare to covered conductor or from covered to bare conductor, all locations with bare conductor will use porcelain insulators and bare tie wires. Covered conductor will relate to a dead end and will have a dead-end cover. Bare conductor will be connected to the stripped portion of the covered conductor. See DCS Section 3000-00, Sheet 2 of 2.
- Dead end covered conductor (no splices to connect dead ends).
- When a splice is needed due to broken primary (unlikely scenario), strip the covering back enough to apply the splice, apply the splice and then cover the splice in self-fusing tape.
- Grounding will require making connections with the grounding jumpers at locations where the covered conductor has been stripped. Minimizing new locations where the conductor is stripped is recommended. Covering up stripped portions of the conductor should be done with self-fusing tape.

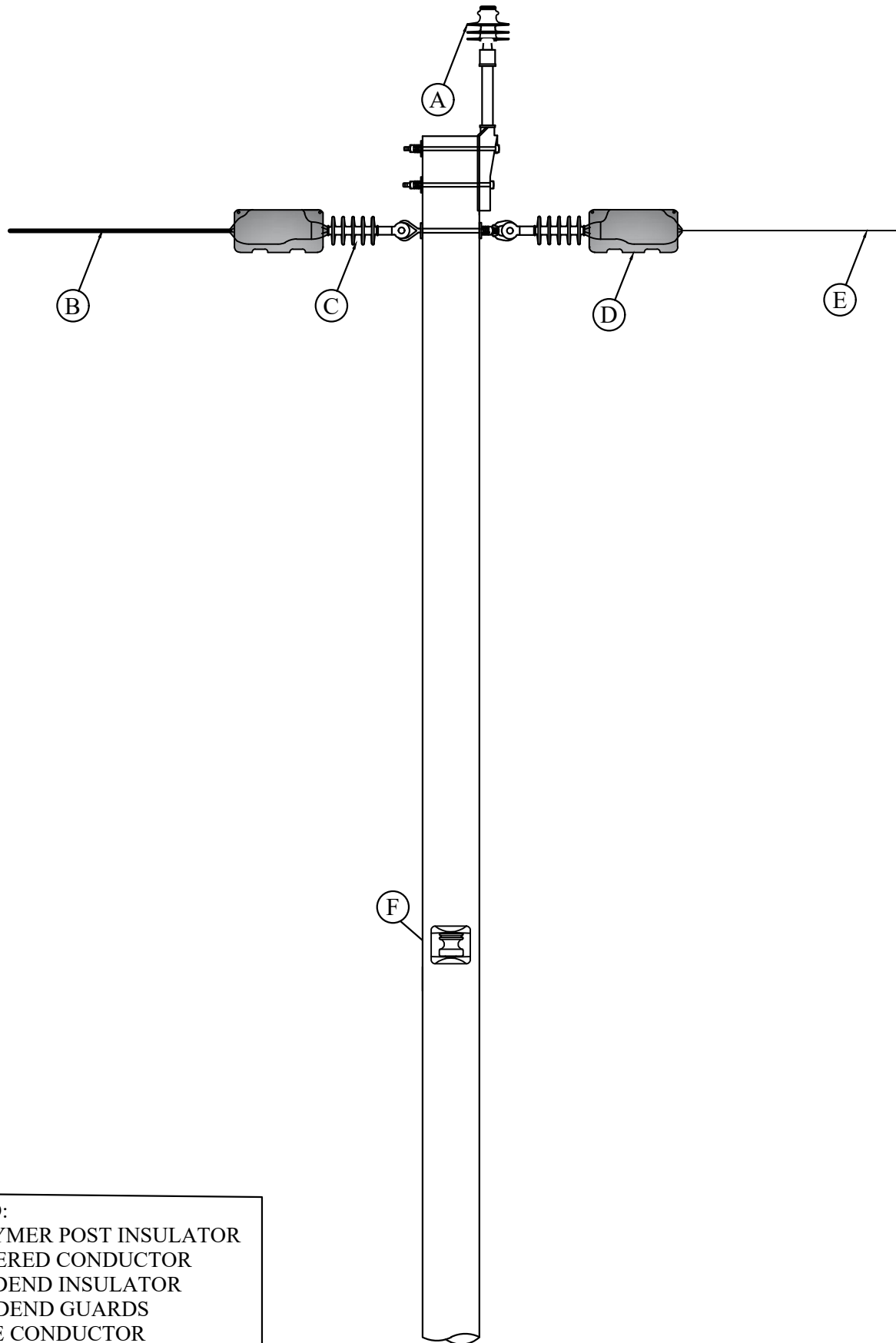

LEGEND:

- A - POLYMER POST INSULATOR
- B - COVERED CONDUCTOR
- C - DEADEND INSULATOR
- D - DEADEND GUARDS
- E - BARE CONDUCTOR
- F - ONE POINT RACK

**Covered Conductor (CC)**

Covered Conductors, often referred to as tree wires, are an essential part of overhead distribution systems, especially in areas with vegetation or where enhanced durability and insulation are required.

**Special Notes:**

1. For installations with primary covered conductor, the neutral conductors will not utilize covered conductor.
2. Austin Energy will utilize 795 AAC (3-Layer Covered Conductor) and 1/0 ACSR (3-Layer Covered Conductor), rated at 15kV, for all overhead primary covered conductor installations.

**Conductor Material Options:**

- **Aluminum Conductor Steel-Reinforced (ACSR):** Preferred for general applications due to its strength-to-weight ratio.
- **All Aluminum Conductor (AAC), Compact:** Preferred for general applications due to its ampacity-to-weight ratio.

**Conductor Shield (Layer 1)**

- **Material:** Semi-conducting thermoset polymer.
- **Purpose:**
  - Reduces electrical stress concentrations caused by magnetic flux lines around individual conductor strands.
  - Encircles and transforms individual strands into a unified conducting cylinder, ensuring uniform electrical performance.
- **Benefits:** Enhances the lifespan of the covered conductor by mitigating electrical stress and delaying failure during incidental contact.

**Inner Layer (Layer 2)**

- **Material:** Crosslinked Low-Density Polyethylene (XL-LDPE).
- **Function:**
  - Provides primary insulation to prevent phase-to-phase and phase-to-ground faults.
  - Contributes to the high impulse strength of the conductor.
- **Role in Reliability:** Protects the conductor core from electrical and mechanical impacts.

**Outer Layer (Layer 3)**

- **Material:** Crosslinked High-Density Polyethylene (XL-HDPE).
- **Function:**
  - Offers an additional insulating barrier similar to the inner layer.
  - Provides abrasion and impact resistance due to its high-density structure.
  - Track-resistant properties minimize surface electrical tracking, reducing erosion and maintaining insulation integrity over time.
- **Additional Features:**
  - UV stability ensures durability against prolonged sunlight exposure, preventing degradation.
- **Mechanical Strength:** The tough outer layer is crucial for environments with mechanical hazards.

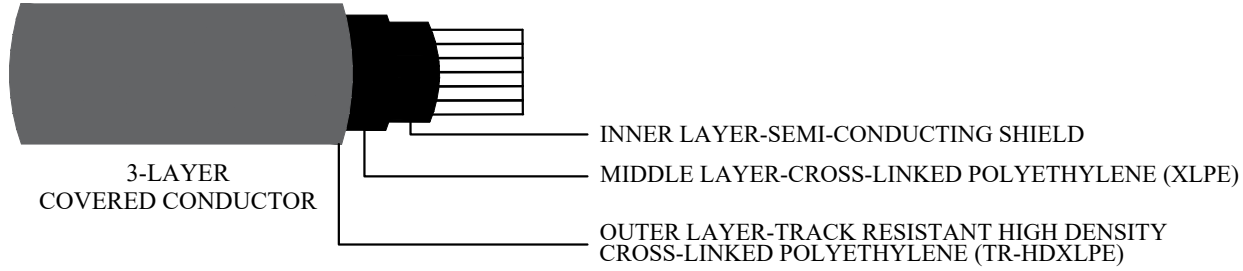

15KV COVERED CONDUCTOR (TREE WIRE)					
CONDUCTOR SIZE	CONDUCTOR TYPE (STRANDING)	WEIGHT (lb/ft)	CONDUCTOR DIAMETER (in)	OVERALL DIAMETER (in)	AMPACITY* PER CONDUCTOR (amps)
COMPACT 1/0 AWG	ACSR (6/1)	0.2688	0.398	0.728	282
COMPACT 795 KCMIL	AAC (37)	1.0460	0.932	1.292	935

**\*1/0 COVERED CONDUCTOR OPERATING RATING CRITERIA:**

- RATED STRENGTH = 4,380 LBS
- AMBIENT TEMPERATURE = 25C
- CONDUCTOR TEMPERATURE = 90C
- LOAD FACTOR = 100%
- WIND SPEED = 2 FT/SEC
- COEFFICIENT OF EMISSIVITY = 0.90^
- COEFFICIENT OF ABSORPTION = 0.90^

**\*795 COVERED CONDUCTOR OPERATING RATING CRITERIA:**

- RATED STRENGTH = 15,600 LBS
- AMBIENT TEMPERATURE = 25C
- CONDUCTOR TEMPERATURE = 90C
- LOAD FACTOR = 100%
- WIND SPEED = 2 FT/SEC
- COEFFICIENT OF EMISSIVITY = 0.90^
- COEFFICIENT OF ABSORPTION = 0.90^

^EMISSIVITY & ABSORBTIVITY VALUES DETERMINED THROUGH DISCUSSIONS WITH THE MANUFACTURER AND REVIEW OF IEEE 738 SECTION 5.4

**WILDLIFE GUARD NOTES**

Proper wildlife guards should be installed in conjunction with covered conductors to mitigate outages caused by wildlife interference. The wildlife guards which have been specified include the following:

- Deadend Guard
- Wedge Clamp Guard
- Stirrup / Hot Line Clamp Guard
- Self-Fusing Tape (used to cover splices on the covered conductor system)
- Lightning Arrester Guard
- Fuse Cutout Guard Kit (includes a top and bottom covering for typical distribution fuses)
- Transformer Bushing Guard

Distribution Standards should be contacted for situations when new wildlife guards are needed.

KEY NOTE: Wildlife protection material is for incidental wildlife contact only. Guards are not rated for personal protection and should be treated as bare wire.

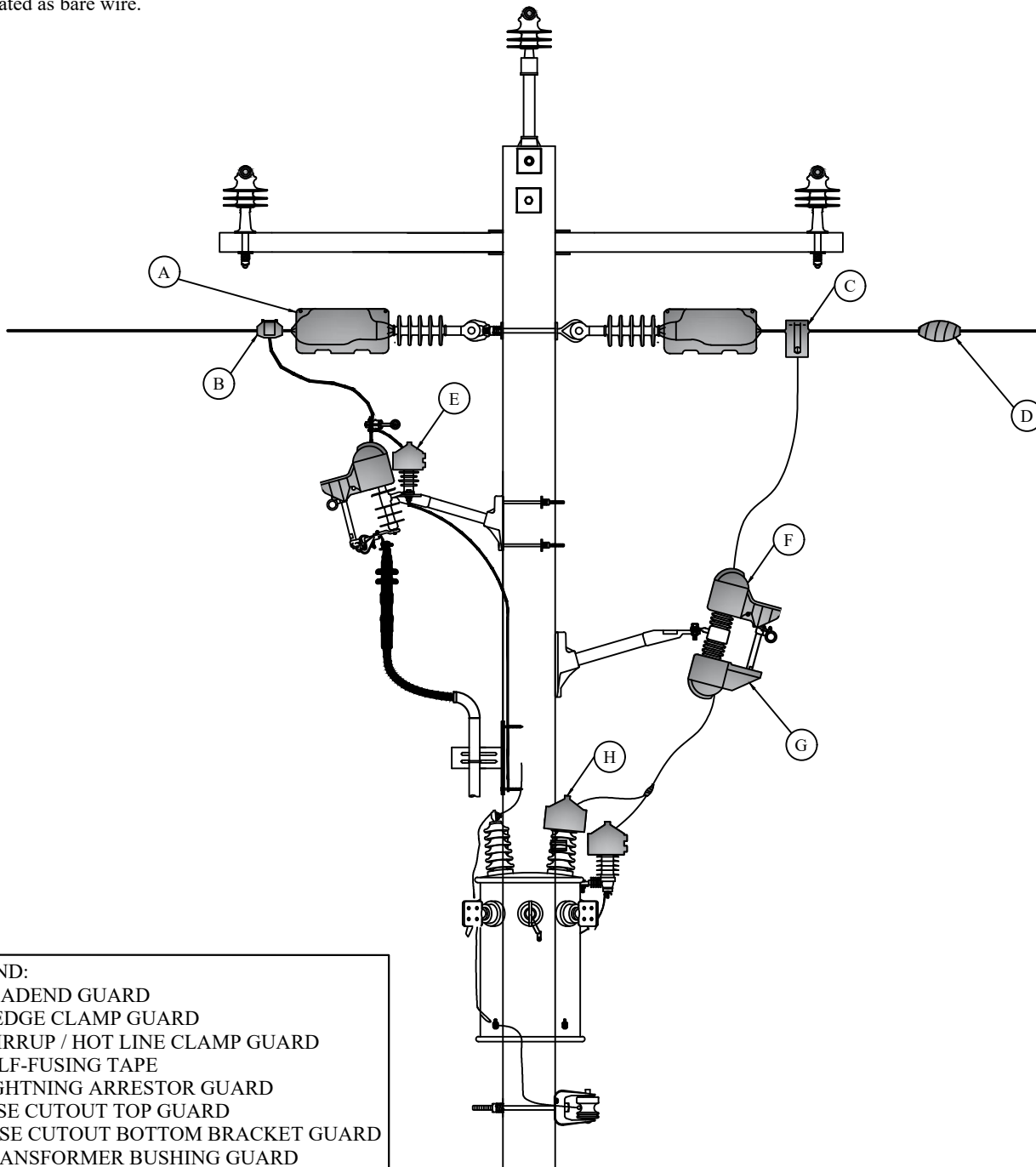

LEGEND:  
 A - DEADEND GUARD  
 B - WEDGE CLAMP GUARD  
 C - STIRRUP / HOT LINE CLAMP GUARD  
 D - SELF-FUSING TAPE  
 E - LIGHTNING ARRESTOR GUARD  
 F - FUSE CUTOUT TOP GUARD  
 G - FUSE CUTOUT BOTTOM BRACKET GUARD  
 H - TRANSFORMER BUSHING GUARD

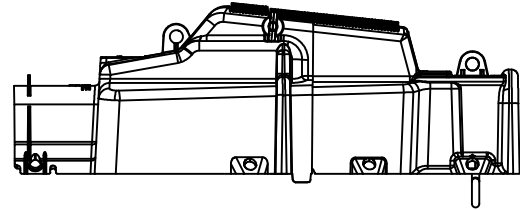
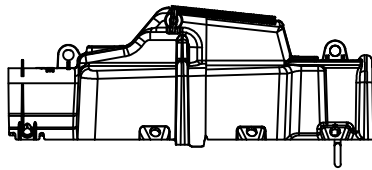
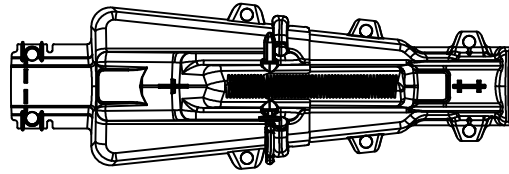
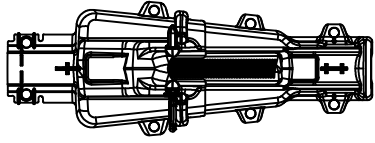

30002101

30002102

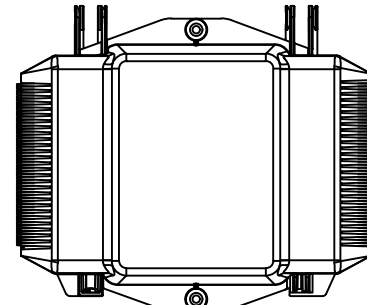
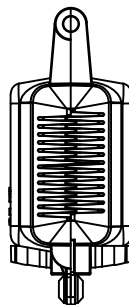
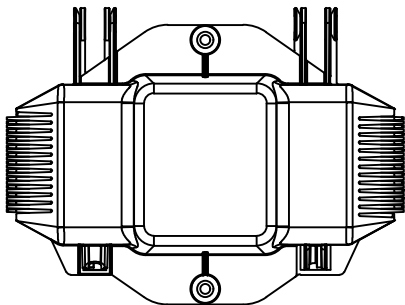
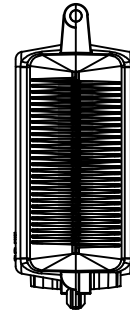
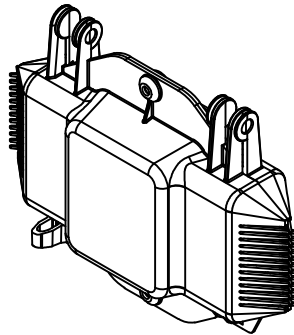
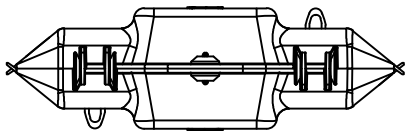

30002111  
30002112

CU-REF	CU-ID	CU-DESCRIPTION
30002101	DEADENDCLMPCVRM-CC	DEADEND CLAMP COVER MEDIUM- CC
30002102	DEADENDCLMPCVRLG-CC	DEADEND CLAMP COVER LARGE- CC
30002111	WEDGCLMPGARDM-CC	WEDGE CLAMP GUARD MEDIUM - CC
30002112	WEDGCLMPGARDL-CC	WEDGE CLAMP GUARD LARGE - CC

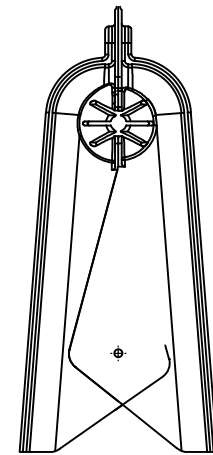
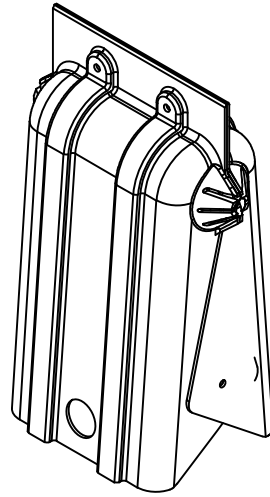
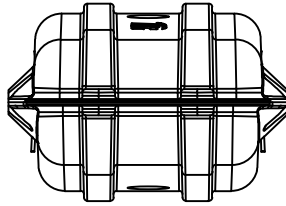

3000-22-01

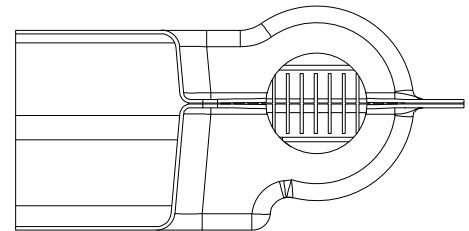
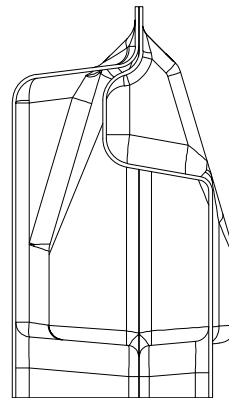
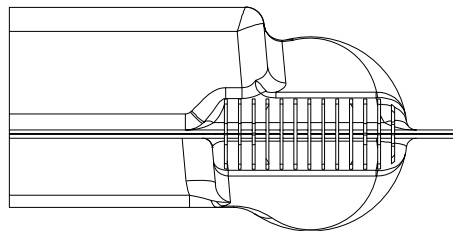
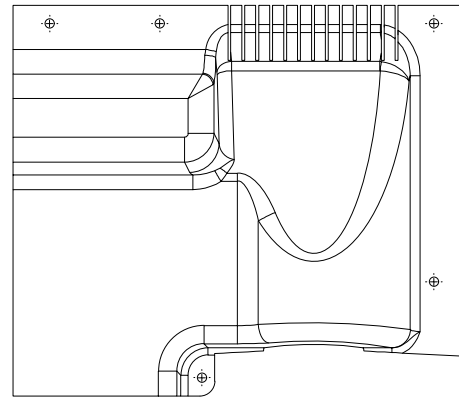
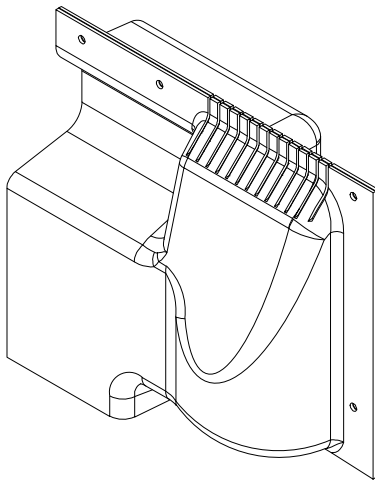

3000-22-11

CU-REF	CU-ID	CU-DESCRIPTION
30002201	STRPHTLCLMPCVR-CC	STIRRUP HOTLINE CLAMP COVER - CC
30002211	DISCONNECTCVR-CC	DISCONNECT COVER - CC

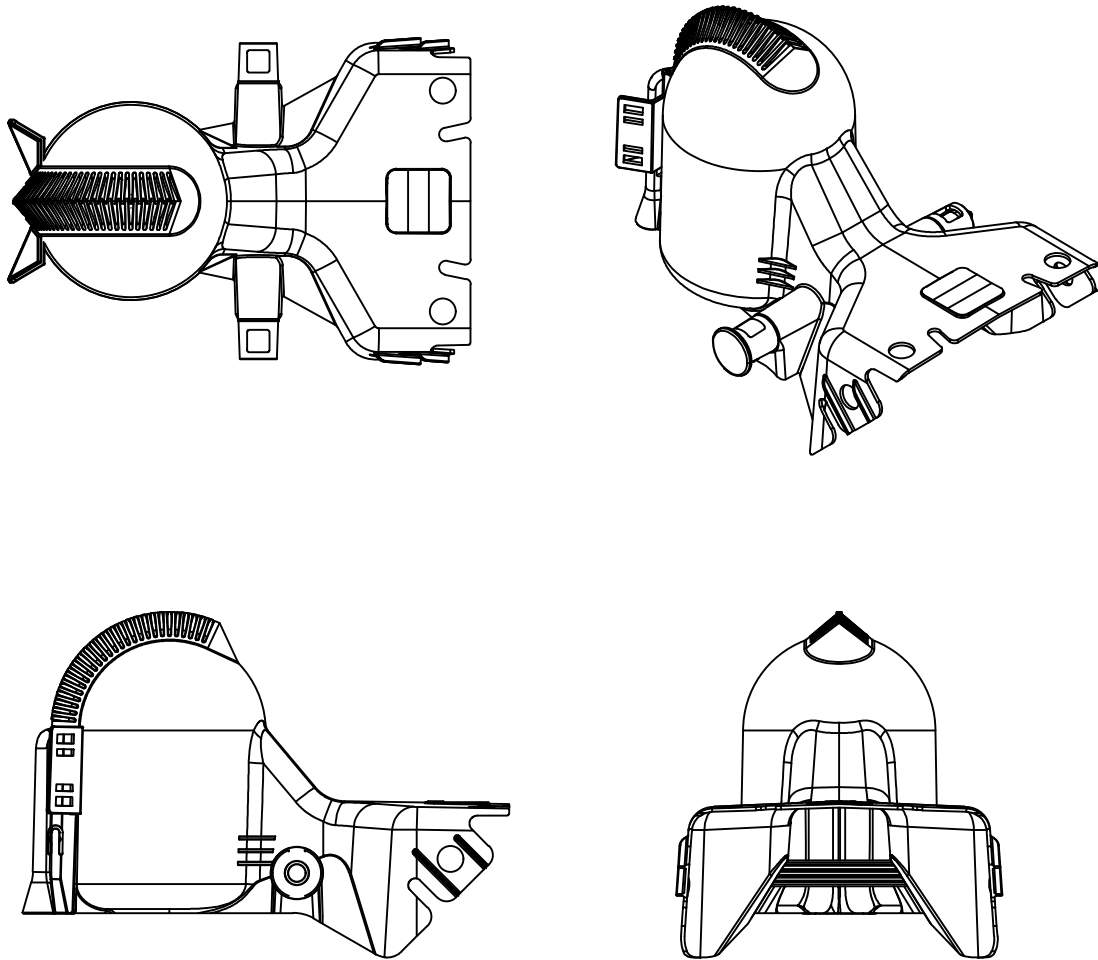

3000-23-01

CU-REF	CU-ID	CU-DESCRIPTION
30002301	FUSCUTOUTCVRKIT-CC	FUSE CUTOUT COVER KIT - CC

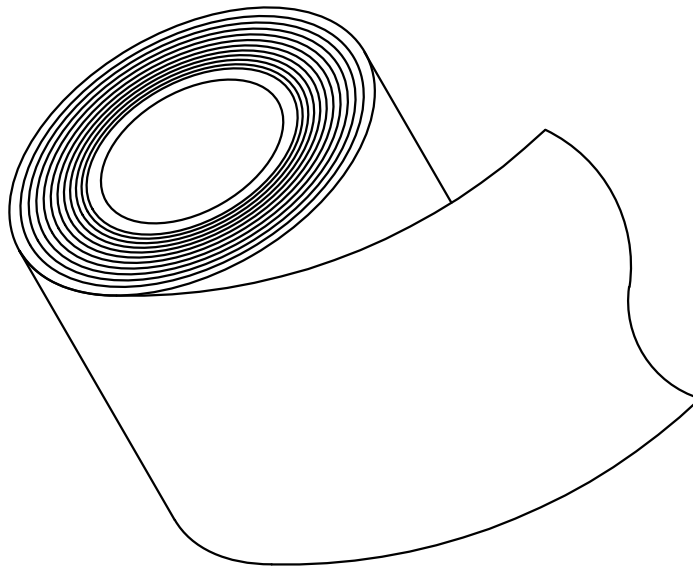

3000-24-01

NOTE: SEE 1368-05 FOR INSULATING TUBING

CU-REF	CU-ID	CU-DESCRIPTION
30002401	TAPESLFFSINGINSU2-1/2INX36FT-CC	TAPE SELF FUSING INSU 2-1/2 IN X 36 FT - CC

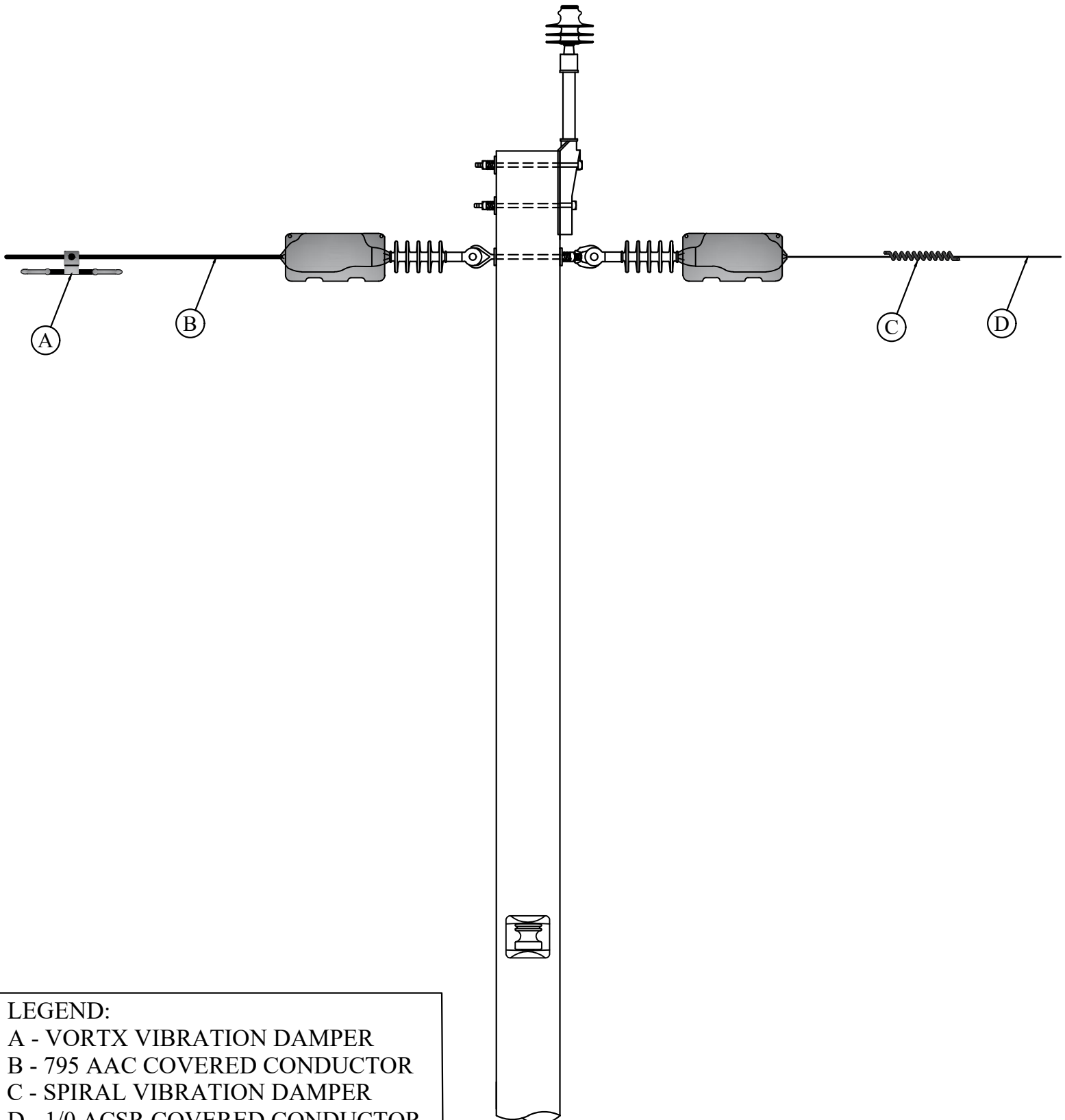

**LEGEND:**  
 A - VORTX VIBRATION DAMPER  
 B - 795 AAC COVERED CONDUCTOR  
 C - SPIRAL VIBRATION DAMPER  
 D - 1/0 ACSR COVERED CONDUCTOR

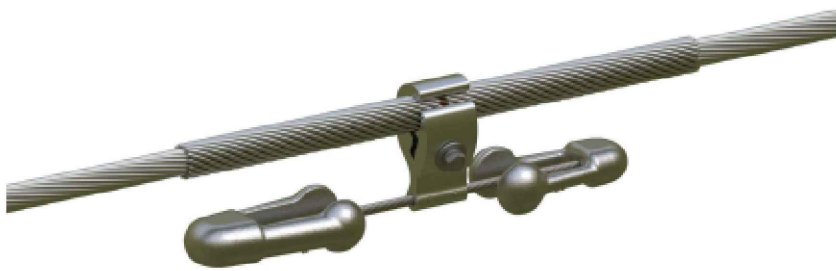
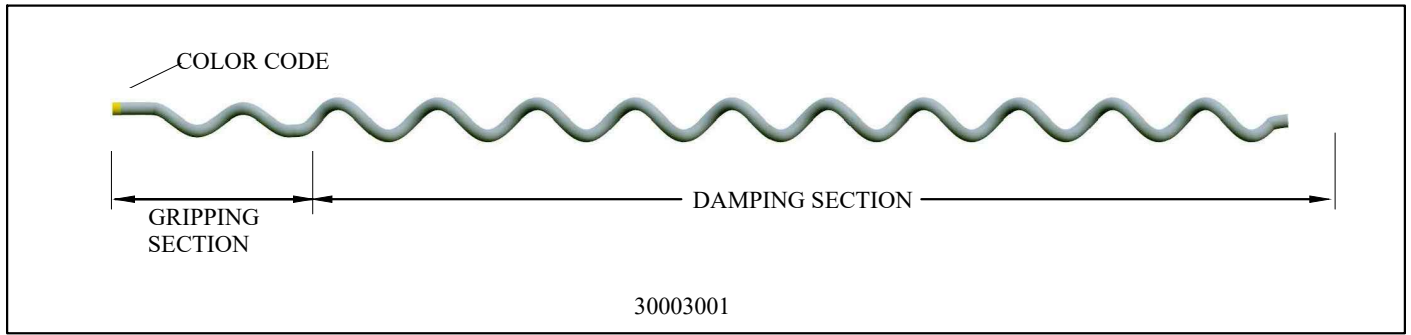

30003002  
30003003

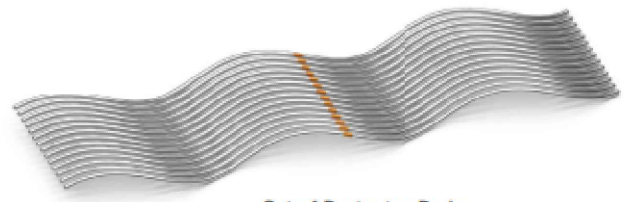

Set of Protector Rods

CU-REF	CU-ID	CU-DESCRIPTION
30003101	SPRLVBRTNDMPR1/0-CC	SPIRAL VIBRATION DAMPENERS 1/0 - CC
30003002	STCKBRIDGEVBRTNDMPR795-CC	STOCKBRIDGE VIBRATION DAMPENERS 795 - CC
30003003	STCKBRIDGEVBRTNDMPR796PROTRD-CC	STOCKBRIDGE VIBRATION DAMPENERS 795 PROTECTOR ROD - CC